

版本号	<p style="text-align: center;"><u>RFL-P20QS/30QS</u></p> <p style="text-align: center;"><u>20QS/30QS 激光器英文说明书</u></p> <p style="text-align: center;"><u>RFL-P20QS/30QS · JS02</u></p> <p style="text-align: center;">部 门 <u>脉冲激光器技术研究部</u></p> <p style="text-align: center;">编 写 <u>颜鹏晖 20210303</u></p> <p style="text-align: center;">校 对 <u>刘 红 20210305</u></p> <p style="text-align: center;">审 核 <u>李 科 20210305</u></p> <p style="text-align: center;">标 审 <u>李其军 20210305</u></p> <p style="text-align: center;">批 准 <u>黄 保 20210308</u></p> <p style="text-align: center;">武汉锐科光纤激光技术股份有限公司</p>	密级	内部		
A0		阶段 标记		C	
会签					
谢良					
夏巨江					
旧底图登记号					
/					
底图登记号					
/					



User Instruction

RFL-P20QS
RFL-P30QS

Wuhan Raycus Fiber Laser Technologies CO., Ltd.

2021

Safety Information

Please read this instruction carefully and familiarize yourself with the information we have provided before you use the product. In this brochure, important operation procedures, safety and other information are provided for you and all future users. In order to ensure operating safely and optimal performance of the product, please do according to following warnings, cautions and other information.

- a) Raycus pulsed fiber laser is classified as a high power Class IV laser device. Before supplying the power to the device, please make sure that the correct voltage of 24VDC power source is connected and the anode and cathode are right. Failure to connect power source correctly will cause damage to the device.
- b) The device emits invisible 1060~1085nm wavelength light with average power 20W~30W. Do not expose your eyes or skin to the radiation of the laser.
- c) Do not take apart the device, because there are no replaceable accessories available for users to use. Any maintenance can only be proceeded in Raycus.
- d) Do not look into the light output end directly. Use appropriate laser safety eyewear when operating the device.

Safety labels and locations



Be careful
Avoid direct laser irradiation

The two labels above is located on the top of the cover of the device, representing laser radicalization.

Content

1. Description	1
1.1. Product description	1
1.2. Actual configuration list	1
1.3. Environmental requirements and cautions.....	1
1.4. Specifications.....	2
2. Mounting.....	3
2.1 Mounting dimensions	3
2.2 Method of installation.....	3
3. Control Interface	4
4. Operation Regulations.....	6
4.1 Pre-inspection	6
4.2 Operation procedures.....	7
4.3 Cautions	7
5. Instructions for warranty, return and maintenance	8
5.1 General warranty	8
5.2 Limitations of warranty	8
5.3 Service and repairs.....	8

1. Description

1.1. Product description

Raycus pulsed laser is an ideal high power laser source with high speed and high efficiency. It is specially designed for industrial laser making system and other applications.

Compared with traditional lasers, pulsed laser has some unique advantages in increasing the conversion efficiency of the pump light 10 times higher. Its low power consumption and automotive design make it appropriate for operating both in and outside the lab. Besides, it is exquisite and convenient for its independence in placement, free time in using and facility in connecting to equipment directly.

The device can emit 1060~1085nm wavelength pulsed light under the control of industrial laser's standard interface driven by 24VDC power source.

1.2. Actual configuration list

Table 1. Configuration list

Items	Quantity	Remark
Fiber Laser module	1	

1.3. Environmental requirements and cautions

Pulsed laser should be driven by 24VDC \pm 1V power source.

- a) Caution: Make sure the corresponding wires of the device are properly grounded.
- b) All the maintenance to the device should only be done by Raycus, because there is no replacement or accessory provided with the device. Please do not try to damage the labels or open the cover in order to prevent against electric shock, or the warranty will be invalid.
- c) The output head of the product is connected with an optical cable. Please be careful handling the output head. Avoid dirt and any other contaminations. Please use the specialized lens paper when cleaning the lens. Please lid the laser with protective cover of the light isolator to be against dirt only when the laser is not installed in the device or not in working.
- d) If the operating the device fails to follow this instruction, the protective function will be weakened. Therefore, it should be used under normal conditions.
- e) Do not install the collimating device into the output head when the laser device is in working.

- f) The device has three cooling fans at the rear panel to dissipate heat. In order to guarantee enough airflow to help giving heat off, there must be a space of at least 10cm's width for airflow in front and rear side of the device. As the cooling fans are working at blow condition, if laser is mounted in a cabinet with fans, the direction should be same as laser's fans.
- g) Do not look into the output head of the device directly. Please do wear appropriate laser safety eyewear during the time when operating the device.
- h) Make sure the pulse repetition rate higher than 30 KHz.
- i) For the longest time without pulse is only 100 us. If there is no pulse output, please stopmarking at once, to avoid further damage of the device.
- j) Power source sudden interruption will do great harm to the laser device. Please make sure the power supply works continuously.

1.4. Specifications

Table 2. 20QS、30QS pulsed fiber laser specifications

Pulsed fiber laser	20QS	30QS
Wavelength (nm)	1060~1085	1060~1085
Polarization	Random	Random
Optical isolator	Yes	Yes
Nominal average output power (W)	≥20	≥30
Single pulse energy (mJ)	0.66@30kHz	0.75@40kHz
Beam quality (M2)	<1.6	<1.6
Beam Diameter (mm)	6~8	6~8
Pulse duration (ns)	120-150@30kHz	130-160@40kHz
Pulse repetition rate (kHz)	30-60	40-60
Output Power Tunability (%)	10-100	10-100
Output Fiber Cable length (m)	3.0	3.0
Working voltage (VDC)	24±1	24±1
Power consumption (20°C) (W)	150	200
Cooling	Forced Air Cooled	Forced Air Cooled
Dimension W×D×H (mm)	290*215*95	290*215*95
Operating temperature (°C)	0°C~40°C	0°C~40°C
Store temperature (°C)	-10°C~60°C	-10°C~60°C
humidity (%)	30%~85%	30%~85%

2. Mounting

2.1 Mounting dimensions

- a) Fiber Laser module dimensions (As shown in Fig. 1).

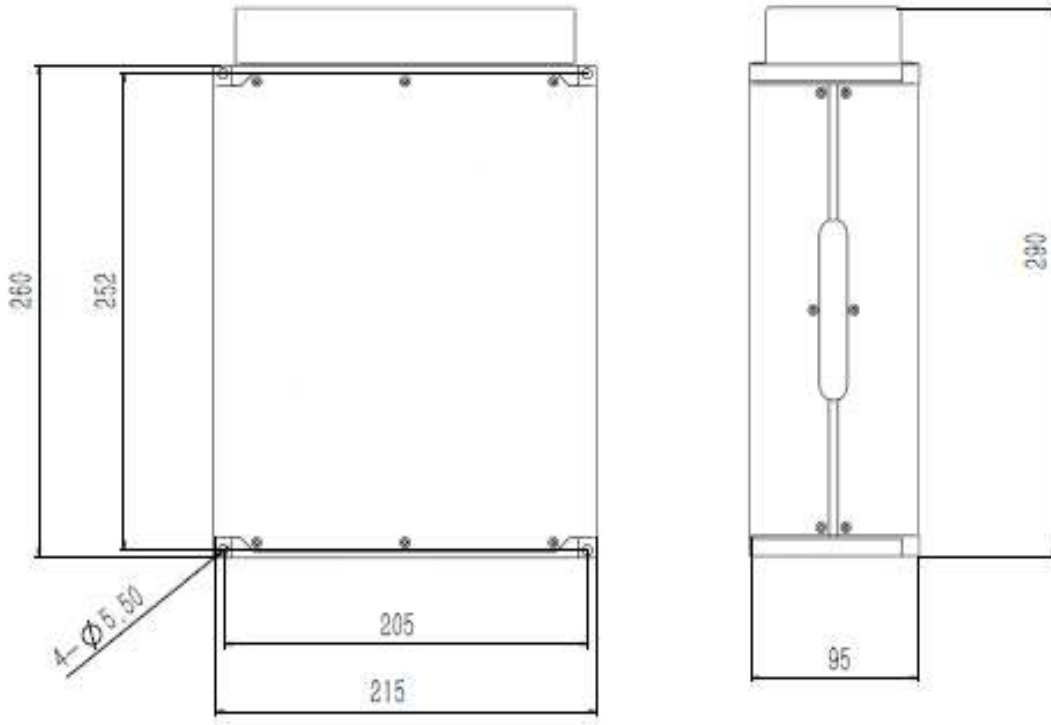

Figure 1. Dimension drawing of laser module(Unit: mm).

- b) Isolated output head dimensions (As shown in Fig. 2).

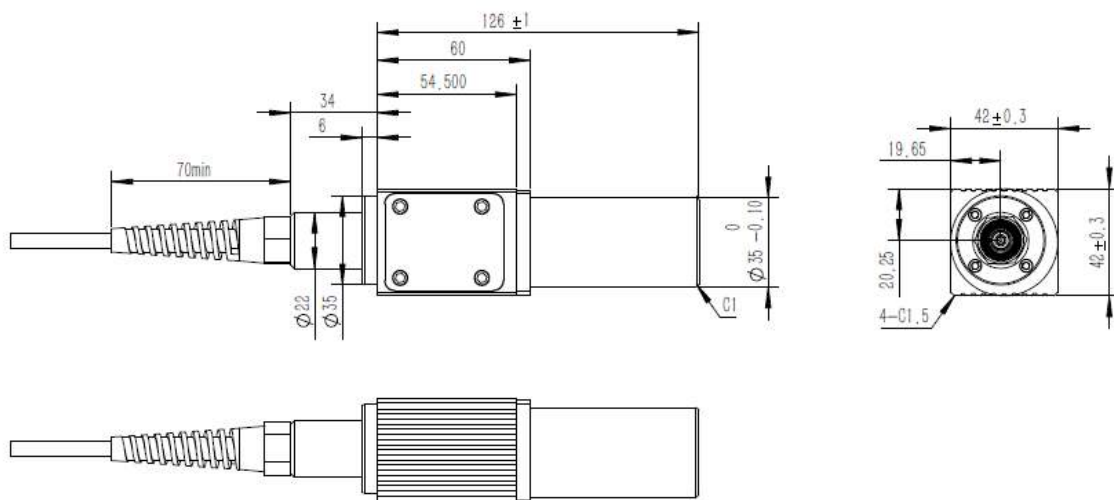

Figure 2. Dimension drawing of output isolator (Unit: mm).

2.2 Method of installation

- a) Fix the module stable to the bracket and keep the laser in good ventilation.

- b) Connect the power line to 24VDC power and ensure enough DC output power. Keep it clear to the polarity of the electric current: anode-brown; cathode-blue; PE-yellow and green. The definition figure is shown in Fig. 3.

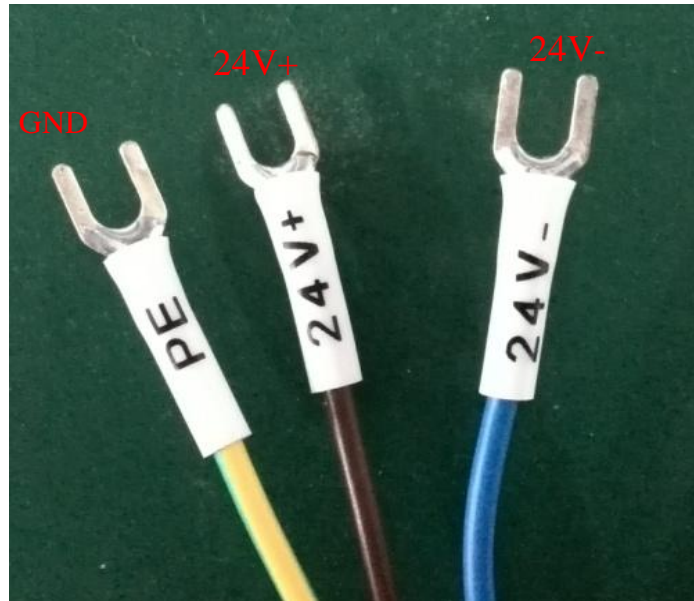

Figure 3. Definition of power line wires

- c) Make sure that the interface of the external controller matches the laser and the control cable is well connected to the laser's interface. The recommended electrical connection is shown in Fig. 4.

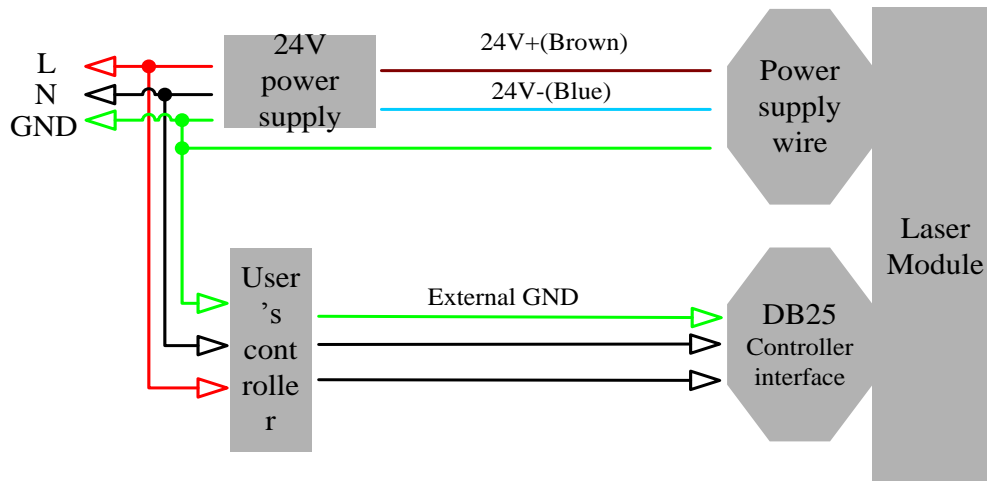

Figure 4. Schematic of recommended electrical connection

- d) The bending radius of the delivery fiber should not less than 15cm.

3. Control Interface

There are DB9 and DB25 interfaces at the rear of the laser. The DB9 is a RS232 interface only used for debugging, no needs to connect. And DB25 is the joint interface connecting control

system with laser device, please make sure the connection is reliable before operating. Feet of the DB25 are defined as follows in Fig. 5.

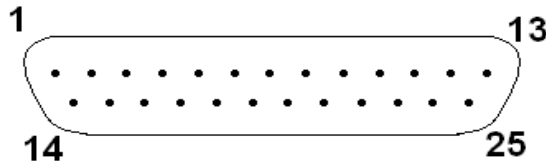

Figure 5. Connect port of controller

Table 3 Definition of connect ports of controller

PIN No.	Name	Description
1-8 (D0-D7)	Power Setting	8 bit Parallel port; D0 is minimum bit and D7 is maximum bit; Range: 0-255 (hexadecimal: 0X00-0XFF); 0 is minimum power and 255 is maximum power.
10,13-15,24-25	Ground	Digital GND
11,12,16,21	Laser alarms status	see alarm codes in the table below
17	VCC	+5V DC power supply input, providing power for inside chips of DB25 to ensure that the input and output signals are valid.
18	EE	Emission Enable (EE) signal. HIGH: Emission Enable LOW or disconnected: Emission Disable
19	EM	Emission Modulation (EM) input. HIGH (>3V): Emission ON LOW or disconnected (<1V): Emission OFF
20	Sync	Pulse Repetition Rate (Synchronization) input, square wave.
22	Guide Laser signal	Guide Laser (red diode) ON/OFF input.
9,23	Obligate PIN	Reserved for Raycus only

- a) The pump current of diode laser and the laser output power are controlled by setting the value of PIN1-PIN8 (TTL level). PIN1-PIN8 can be set from 0 ~ 255 , corresponding to the laser output power from 0~100% (the actual laser power may not be strictly linear with the setting value). The relationship between PIN value and output power is shown in Table 4.
- b) PIN 17 is the external 5V input, providing power supply for alarm signal: input current >20mA.
- c) The external input signal (PIN 1-8, 18-20, 22) are connected to the optical coupler inside the system. Input voltage 3V-5V are defined as digital High, below 1V are

defined as digital Low. The input current should be above 2mA.

- d) Alarms status: Pins 11, 12, 16 and 21 are the alarm and status outputs which driven by +5V power from PIN 17. PIN 12 is reserved (always be high). These pins indicate the following device states.

Table 4 Definition of power control PIN value

	Setting 1	Setting 2	Setting 3	Setting 4	Setting 5
PIN 1	0	0	0	0	1
PIN 2	0	0	0	0	1
PIN 3	0	0	0	0	1
PIN 4	0	0	0	0	1
PIN 5	0	0	0	1	1
PIN 6	0	0	1	1	1
PIN 7	0	1	1	1	1
PIN 8	1	1	1	1	1
Current	~50 %	~75 %	~87.5 %	~93.75 %	100%

Table 5 Definition of alarm status.

PIN 12	PIN 11	PIN 16	PIN 21	Alarm item
×	Low	Low	Low	Temperature alarm
×	Low	Low	High	Normal
×	Low	High	High	System alarm
×	High	Low	Low	Supply voltage

- e) PIN 10、13、14、15、24、25 are all digital GND.
- f) PIN 20 is the pulse repeating rate signal(PRR, TTL level). If the PRR need to be changed during the work, it must be changed 5ms earlier than the EM signal turning into high.
- g) PIN 22 is the guide laser (red diode)on/off signal. High level switch on the guide laser while low level switch off the guide laser.

4. Operation Regulations

4.1 Pre-inspection

- a) Make sure the device appearance is in good condition and the output fiber is neither excessively bended nor broken.

- b) Make sure signal line of laser and marking system are properly connected.

4.2 Operation procedures

- a) Starting procedures

Please make sure the control system is on before you turn on the fiber laser. Only after at least 1 minute since the power turned on, the subsequent operations can be preceded.

- b) Frequency set introductions

For model P20QS, the frequency setting range is from 30KHz to 60KHz.

For model P30QS, the frequency setting range is from 40KHz to 60KHz.

- c) Laser marking checking

For the device initial testing, first turn the power down to zero without turning on the marking system after the device is successfully started. Then draw a quadrature, marking continuously while slowly increasing the power from zero to 100% at the same time. Meanwhile, use a ceramic material to observe the laser and the laser should become stronger, otherwise shut down the device and check. If operating normally, the marking system can be used in common order afterwards.

4.3 Cautions

- a) Marking frequency must be in the range of 30~60 KHz for P20QS, 40~60 KHz for P30QS.

- b) It should not modulate the frequency while marking.

Stop marking first before shutting down the device, then turn the power down to zero and cut the power off.

5. Instructions for warranty, return and maintenance

5.1 General warranty

All products are warranted by Raycus against defects and problems in materials and workmanship during the warranty period according to the purchase order or specifications and we guarantee the product will accord with the specification under normal use.

Raycus has the right to choose to repair or replace any product that proves to be defective in materials and workmanship selectively during the warranty period. Only products with particular defects are under warranty. Raycus reserves the right to issue a credit note for any defective products produced in normal conditions.

5.2 Limitations of warranty

The warranty does not cover the maintenance or reimbursement of our product of which the problem results from tampering, disassembling, misuse, accident, modification, unsuitable physical or operating environment, improper maintenance, damages due to excessive use or not following the instructions caused by those who are not from Raycus. Customer has the responsibility to understand and follow this instruction to use the device. Any damage caused by fault operating is not warranted. Accessories and fiber connectors are excluded in this warranty.

According to the warranty, client should write to us within 31 days since the defect is discovered. This warranty does not involve any other party, including specified buyer, end-user or customer and any parts, equipment or other products produced by other companies.

5.3 Service and repairs

Raycus is responsible for all the maintenance, for there is no accessory available inside for users to use. Please contact Raycus as soon as possible when problems under warranty about maintenance happen to the product. The product returned with permission should be placed in a suitable container. If any damage happens to the product, please notify the carrier in document immediately.

All the items about warranty and service above provided by Raycus are for users' reference, formal contents about warranty and service are subject to the contract.

Wuhan Raycus Fiber Laser Technologies Co. Ltd.

All Rights Reserved.