



Wuhan Raycus Fiber Laser Technologies CO., LTD.
P200MX Pulsed Fiber Laser User Instruction V1

User Instruction

RFL-P200MX

Wuhan Raycus Fiber Laser Technologies CO., Ltd.

2021

Safety Information

Please read this instruction carefully and familiarize yourself with the information we have provided before you use the product. In this brochure, important operation procedures, safety and other information are provided for you and all future users. In order to ensure operating safely and optimal performance of the product, please act according to following warnings, cautions and other information.

- Raycus pulsed fiber laser is classified as a high power Class IV laser device. Before supplying the power to the device, please make sure that the correct voltage of 48V DC is connected and the anode and cathode are right. Incorrect polarity or voltage will damage the device.
- The device emits invisible light with a wavelength from $\lambda = 1060\text{nm}$ to $\lambda = 1085\text{nm}$ with average power of 200W. Do not expose your eyes or skin to the radiation of the laser.
- Do not take apart the device, because there are no replaceable accessories available for users to use. Any maintenance can only be proceeded in Raycus.
- Do not directly look into the fiber delivery cable connector. Use appropriate laser safety eye-wear(i.e. laser goggles) when operating the device.

Safety labels and locations



Be careful
Avoid direct laser irradiation

Warning Signs

The two labels above in Figure 1 are located on the top of the cover of the device, representing laser radicalization.

Content

1. Description.....	1
1.1. Product description.....	1
1.2. Actual configuration list.....	1
1.3. Environmental requirements and cautions.....	1
1.4. Specifications.....	2
2. Installation.....	4
2.1. Installation dimensions.....	4
2.2. Method of installation.....	4
3. Control Interface.....	6
3.1. Pre-inspection.....	11
3.2. Operation procedures.....	11
3.3. Marking process notes.....	11
4. Instructions for warranty, return and maintenance.....	12
4.1. General warranty.....	12
4.2. Limitations of warranty.....	12
4.3. Service and repairs.....	12

1. Product Description

1.1. Product description

Raycus pulsed lasers are specially developed for high-speed and efficient laser marking systems. For industrial laser marking machine and other applications provide an ideal high-power laser energy source.

Compared with traditional laser, pulsed laser can increase the conversion efficiency of pump light per watt by more than 10 times. Automatic design for low-volume consumption, suitable for laboratory or outdoor operation, compact, can be placed independently, can be used at any time, can be directly embedded on the user's device.

The device can emit 1060~1085nm wavelength pulsed light under the control of industrial laser's standard interface driven by 48V DC power source and the output power of the power supply needs to be greater than 1000W.

1.2. Actual configuration list

The list of the actual factory configurations of the laser is shown in Table 1.

Table 1

Items	Quantity	Notes
Fiber Laser module	1	
Factory inspection report	1	

1.3. Environmental requirements and cautions

Pulsed laser should be driven by 48V DC \pm 1V power source. The power output of the power supply is above 1000W.

1. Caution: Make sure the corresponding wires of the device are properly grounded.
2. All the maintenance to the device should only be done by Raycus because there is no replacement or accessory provided with the device. To prevent against electric shock Please do not try to damage the labels or open the cover, or the warranty will be invalid.
3. The fiber delivery cable connector of the product is connected with an optical cable. Please be careful when handling the fiber delivery cable connector. Avoid dirt and any other contamination. Please use the specialized lens paper when cleaning the lens. When the laser is not installed on the system equipment and does not produce light, please cover the optical isolator protective cover to avoid dust contamination.
4. If the laser is not used as specified in this instruction manual, the protective function it produces will be weakened. Therefore, the product must be used in a normal environment.

5. When the laser is in operation, it is strictly prohibited to install the output collimator.
6. The laser has seven fans at the tail plate for heat dissipation, which must ensure sufficient airflow for heat dissipation. The laser fan works in a blowing direction, i.e. the direction of airflow is from the fan position to the laser fiber delivery cable connector position. At least 10 cm of ventilation space is left in front and behind the laser. If the laser is installed in a cabinet with its own cooling fan, it must be ensured that the cabinet fan airflow direction is not opposite to the laser airflow direction.
7. Do not look directly at the fiber delivery cable connector, in the operation of the machine to ensure long-term wear to prevent 1 μ m wavelength laser protective eye environment.
8. Maximum use time without pulse is 50×10^{-6} seconds.

1.4. Specifications

Table 2 200MX pulsed fiber laser specifications

No.	Characteristic	Test Condition	Value	Unit
1	Operating Mode	/	Pulsed	/
2	Average output power @ 350ns	RR=1kHz Pmax	$2 \leq P \leq 3$	W
		RR=100kHz Pmax	$100 \leq P \leq 104$	W
		RR=130kHz Pmax	$201 \leq P \leq 208$	W
		RR=600kHz Pmax	$201 \leq P \leq 208$	W
3	Output power adjustment range	/	1-100	%
4	Central emission wavelength	P=Pmax	1064	nm
5	Emission Bandwidth	P=Pmax	≤ 5	nm
6	Output power instability	After 5Hrs/ P=Pmax	≤ 5	%
7	Laser switching ON time	RR=130kHz P=0~90% Pmax	<100	us
8	Laser switching OFF time	RR=130kHz P=100%~10%Pmax	<30	us
9	Pulse repetition frequency	See table 3	1-4000	kHz
10	Output beam diameter@86% power	P=Pmax	6-8	mm
11	Red guide laser power		0.2-1.0	mW
12	Pulse duration	P=Pmax	(10/20/30/60/100/200/250/350)	ns
13	Beam quality, M^2	P=Pmax	≤ 1.8	/
14	Maximum pulse energy	P=Pmax	1.5	mJ
15	Output fiber cable length		3	m

Table 2 shows the performance parameters of the laser at the default pulse width of 350ns.

Table 3 Frequency parameters at different pulse durations for 200MX

No.	Pulse duration waveform/ns	PRFmin/kHZ Min. frequency	Base frequency PRF ₀ /kHZ	Base frequency corresponding power/w	PRFmax/kHZ Maximum frequency	Pmax/W Maximum frequency corresponding power	E _{max} /mJ
1	10	1	3000	200	4000	200	0.06
2	20	1	1200	200	3000	200	0.16
3	30	1	900	200	3000	200	0.22
4	60	1	550	200	2000	200	0.36
5	100	1	350	200	1000	200	0.57
6	200	1	170	200	1000	200	1.17
7	250	1	150	200	900	200	1.33
8	350	1	130	200	600	200	1.53
9	CW	/				200	CW

2. Installation

2.1. Installation dimensions

1. Dimension drawing

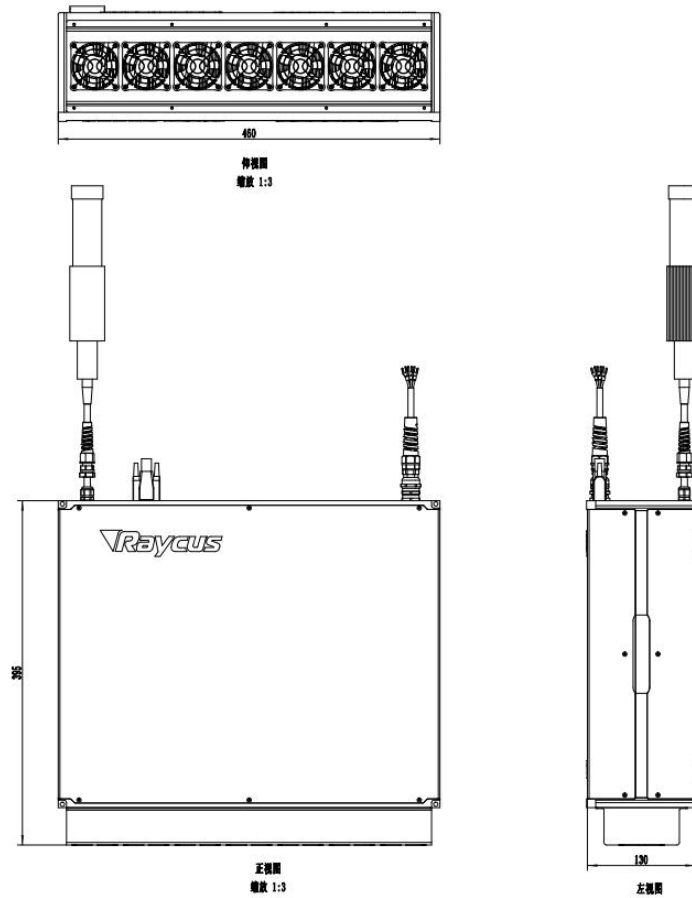

Figure 1 Dimension drawing of laser module (Unit: mm)

2. Optical isolator output head size diagram

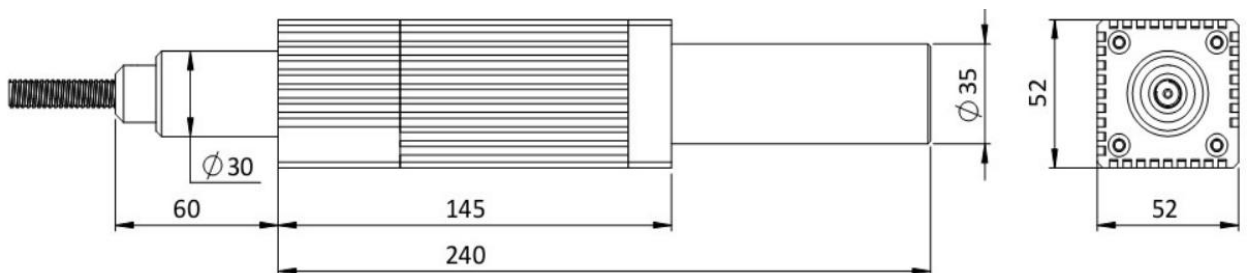

Figure 2 Dimension drawing of output isolator (Unit: mm).

*The output head of the isolator is subject to the final factory product.

2.2. Method of installation

1. Fix the module stable to the bracket and keep the laser in good ventilation.
2. Connect the power line to 48V DC power and ensure enough DC output power. Keep it

clear to the polarity of the electric current: Anode-brown, Cathode-blue, PE-yellow-green.



Figure 3 Definition of power line wires

3. The power consumption of single-mode 200W laser is about 800W, please ensure that the output power of 48V DC power supply reaches more than 1000W.
4. Make sure that the interface of the external controller matches the laser, and the control cable is well connected to the laser's interface. The recommended electrical connection is shown in Figure 4.

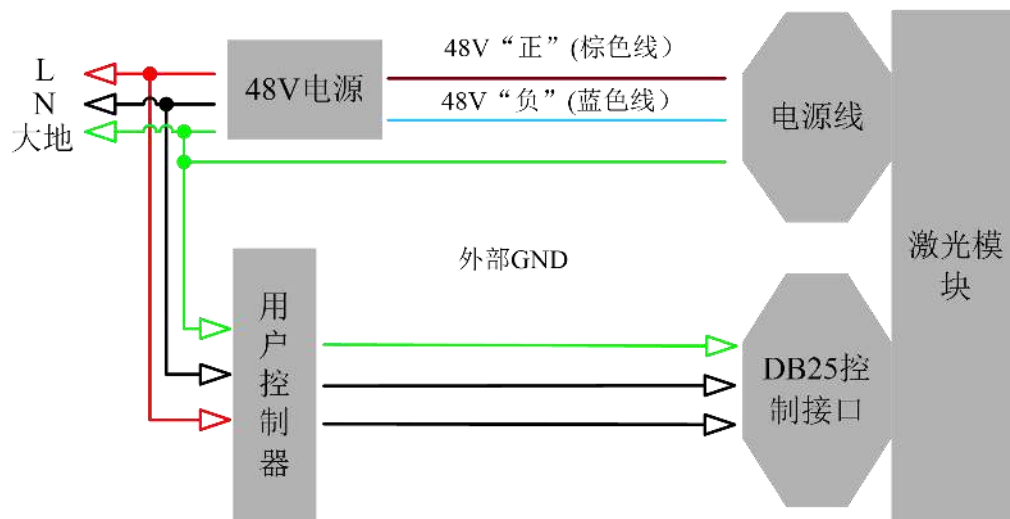

Figure 4 Wiring diagram of recommended electrical connection and power supply

5. The bending radius of the delivery fiber should not exceed 15 cm.

3. Control Interface

The DB25 on the back of the power module is the interface between the control system (e.g. marking machine) and the laser system. Be sure to connect it reliably before working. The pins are defined as follows.

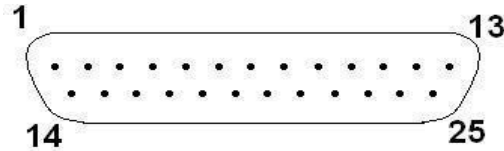

Figure 5 Control interface diagram

Table 4 Control Port Pin Definitions

Pin No.	Name	Description
1-8 (D0-D7)	Power Setting	8 bit Parallel port; D0 is minimum bit and D7 is maximum bit; Range: 0-255 (hexadecimal: 0X00-0XFF). 0: output minimum power; 255: output maximum power
10,13- 15,24,25	Ground	Marking board signal ground (Digital GND)
11,12,16,21	Laser alarms status	Check the details in Table 6.
17	VCC	+5VDC power supply input. Providing power for inside isolate chip of DB25 to ensure that the input and output signal are valid.
18	Pre-emission signal	MO, PA pre-out light signal High level on, low level off
19	Outgoing light signal	Outgoing light signal High level on, low level off
20	Frequency signal	Set laser marking frequency, TTL level, 1KHz-4000KHz
22	Red light signal	High level red light is on, low level red light is off
23	/	Reserved pin, customer is not allowed to connect

- The pump current of the diode laser and the laser output power are controlled by setting the value of Pin1-Pin8 (TTL level). Pin1-Pin8 can be set from 0 to 255, corresponding to the laser output power from 0 to 100% (the actual laser power may not be strictly linear with the setting value). The relationship between Pin value and output power is shown in Table 5.

Table 5 Definition of pin1-8

	Setting 1	Setting 2	Setting 3	Setting 4
Pin 1	0	0	0	0
Pin 2	0	0	0	0
Pin 3	0	0	0	0
Pin 4	0	0	0	0
Pin 5	0	0	0	1
Pin 6	0	0	1	1
Pin 7	0	1	1	1
Pin 8	1	1	1	1
Current	~50 %	~75 %	~87.5 %	~93.75 %

2. Alarm signal definition

Table 6 Alarm signal definition table

12Pin	11Pin	16Pin	21Pin	Alarm Content
Spare	Low	Low	Low	Laser temperature alarm
Spare	High	Low	Low	Power supply failure
Spare	Low	Low	High	Normal
Spare	High	Low	High	Laser not ready
Spare	Low	High	Low	Standby
Spare	Low	High	High	System failure
Spare	High	High	Low	Standby
Spare	High	High	High	Standby

Note: Pin 12 is the backup signal and is always high

- Pin 17 is a 5V input voltage, which is used to supply power to the internal isolated optocoupler of DB25 interface, and the input current is more than 20 mA.
- Laser external input signals (pins 1-8,18,19,20,22) are connected to the optocoupler inside the system to ensure that the input level is digital high in the range of 3.3V-5V, and digital low below 1.7V.
- The laser alarm output signal (pin 11,16,21) is connected to the optocoupler inside the system, and it is necessary to ensure that pin 17 has provided 5V power supply to get a valid signal.
- The connection of digital signal input and output

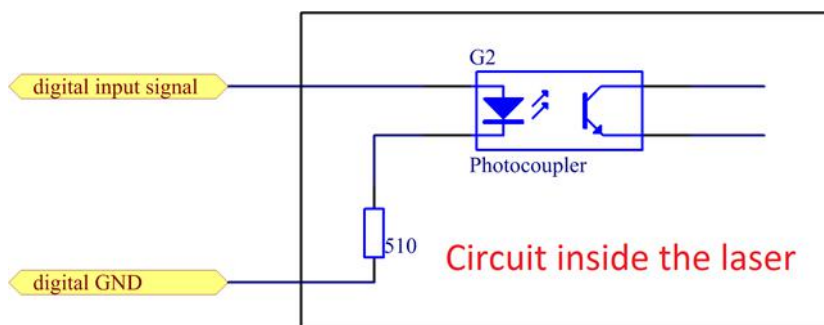

Figure 6 Internal structure of the input control signal

The signal input needs to be able to provide at least 7mA of current. The schematic diagram of the output signal interface circuit is shown in Figure 7.

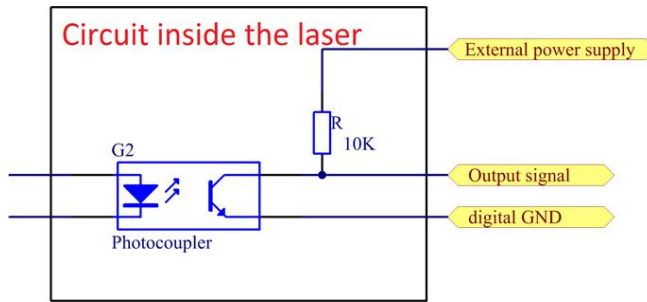

Figure 7: output signal internal

7. DB25 change pulse width interface

Table 7 PIN Definition of Serial Communication

Pin	Name	Description
2	Serial input	Serial data input. The laser latches data on the rising edge of SCLK
3	Serial clock	Serial clock, highest frequency 100K
14	GND	Digital GND
16	SO	Serial clock output, the laser outputs data on the rising edge of SCLK
22	Interface Enable	High: Enable serial communication function of 2,3,16 Low: Disable

Table 8 Command format of setting the laser pulse duration

Frame (1byte)	Command word (1 byte)	Pulse duration(2byte)ns
0xA5	0x01	Big Endian

Table 9 Response format of setting the laser pulse duration

Frame (1byte)	Pulse duration(2byte)ns
0xA5	Big Endian

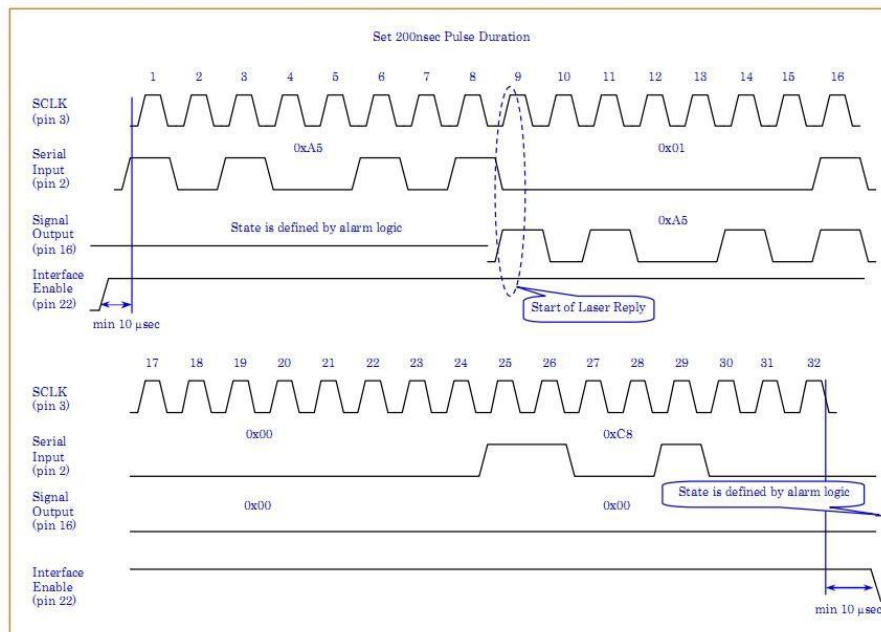

Figure 8. Schematic of laser pulse duration adjustment (200ns)

8 pulse widths of 10, 20, 30, 60, 100, 200, 250 and 350ns can be set.

3.1. Pre-inspection

1. Make sure the device appearance is in good condition and the output fiber is neither excessively bended nor broken.
2. Make sure signal line of laser and marking system are properly connected.

3.2. Operation procedures

1. Starting procedures

Please make sure the control system is on before you turn on the fiber laser. Only after at least 1 minute since the power turned on, the subsequent operations can be proceeded.

2. The frequency setting range is from 1 kHz to 4000 kHz(The actual frequency range of each pulse width is showed in the Table 3).
3. The operation steps of laser marking after the marking machine is turned on checks
For the device initial testing, first turn the power down to 10% without turning on the marking system after the device is successfully started. Then draw a quadrate, marking continuously while slowly increasing the power from 10% to 100% at the same time. Meanwhile, use a ceramic material to observe the laser and the laser should become stronger, otherwise shut down the device and check. If operating normally, the marking system can be used in common order afterwards.

3.3. Cautions

1. Marking frequency must be in the range of 1 kHz to 4000 kHz(The actual frequency range of each pulse duration is showed in the Table 3).
2. Do not modify the frequency while marking.
3. Stop marking first before shutting down the device, then turn the power down to zero and cut the power off.

4. Instructions for warranty, return and maintenance

4.1. General warranty

All products are warranted by Raycus against defects and problems in materials and workmanship during the warranty period according to the purchase order or specifications and we guarantee the product will accord with the specification under normal use.

Raycus has the right to choose to repair or replace any product that proves to be defective in materials and workmanship selectively during the warranty period. Only products with particular defects are under warranty. Raycus reserves the right to issue a credit note for any defective products which are produced in normal conditions.

4.2. Limitations of warranty

The warranty does not cover the maintenance or reimbursement of our product of which the problem results from tampering, disassembling, misuse, accident, modification, unsuitable physical or operating environment, improper maintenance, damages due to excessive use or not following the instructions caused by those who are not from Raycus. Customer has the responsibility to understand and follow this instruction to use the device. Any damage caused by fault operating is not warranted. Accessories and fiber connectors are excluded in this warranty.

According to the warranty, client should write to us within 31days since the defect is discovered. This warranty does not involve any other party, including specified buyer, end-user or customer and any parts, equipment or other products produced by other companies.

4.3. Service and repairs

Raycus is responsible for all the maintenance, there is no accessory available inside for users to use. Please contact Raycus as soon as possible when problems under warranty about maintenance happen to the product. The product returned with permission should be placed in a suitable container. If any damage happens to the product, please notify the carrier in document immediately.

All the items about warranty and service above provided by Raycus are only for reference; formal contents about warranty and service are subject to the contract.