



Global Version
Continuous-Wave Fiber Laser
User Guide
RFL-C3000S-CE

Wuhan Raycus Fiber Laser Technologies Co., Ltd.



TABLE OF CONTENTS

1 Safety Information	4
1.1 Symbols Used in this User Guide	4
1.2 Laser Classification	4
1.3 Safety Labels	5
1.4 Optical Safety	7
1.5 Electrical Safety	7
1.6 Other Safety Rules	8
2 Product Description	9
2.1 Features	9
2.2 Model Configuration	9
2.3 Package Contents	10
2.4 Unpacking and Inspection	10
2.5 Operation Environment	11
2.6 Precautions for Use	12
2.7 Specifications	13
3 Installation	14
3.1 Dimensions	14
3.2 Output Head and Installation	15
3.3 Cooling Requirements	16
3.4 Installation Procedure	18
4 Using the Product	20
4.1 Front Panel	20
4.2 Rear Panel	20
4.3 Power Connection	21
4.4 Interface Definitions	22
4.5 Steps of Installation	27
4.6 Steps of Starting	27
4.7 Functions of the clientware	27
4.8 Control Modes	35
4.9 Guide laser control	40
4.10 The Programming Mode (Waveform Editing)	41
4.11 Modulation signal requirements	42
4.12 Steps of shutting down	43
4.13 Bluetooth app operation description	43
5 Alarms and Solutions	51
5.1 Alarms Display	51
5.2 Alarm solutions	52
6 Warranty, Return and Maintenance	54
6.1 General Warranty	54
6.2 Limitations of Warranty	54
6.3 Service and Repair	54

1 Safety Information

Thank you for choosing Raycus fiber laser. This User Guide provides important safety, operation, warranty and other information. Please read it carefully before you use this product. In order to ensure safe operation and optimal performance of the product, please follow the warnings, cautions, operating procedures and other instructions accordingly.

1.1 Symbols Used in this User Guide

	WARNING: Refers to a potential hazard that may lead to a personal injury or death.
	CAUTION: Refers to a potential hazard that may lead to a minor personal injury or product damage.

1.2 Laser Classification

This series of lasers are classified as a high power Class 4 laser instrument according to the European Community standards EN 60825-1, clause 9. This product emits invisible laser radiation at or around a wavelength of 1080nm, and the total light power radiated from the optical output is greater than 1500W~2000W (depending on model). Direct or indirect exposure of this level of light intensity may cause damage to the eyes or skin. Despite the radiation being invisible, the beam may cause irreversible damage to the retina and/or cornea. Appropriate and approved laser safety eyewear must be worn all the time while the laser is operating.

	<p>WARNING: You must use appropriate laser safety eyewear when this device is operating. The laser safety eyewear is selected according to the range of wavelengths emitted from this product. The end user must ensure that the laser safety eyewear being used protects against light emitted by the device over its entire range of wavelengths. Please verify that the personal protective equipment (e.g. enclosures, viewing windows or viewport, eyewear, etc.) being utilized is adequate for the output power and wavelength ranges listed on the product.</p>
---	--

1.3 Safety Labels

The position of the safety labels on products varies depending on the model of the continuous-wave fiber laser, as shown in Figure 1:

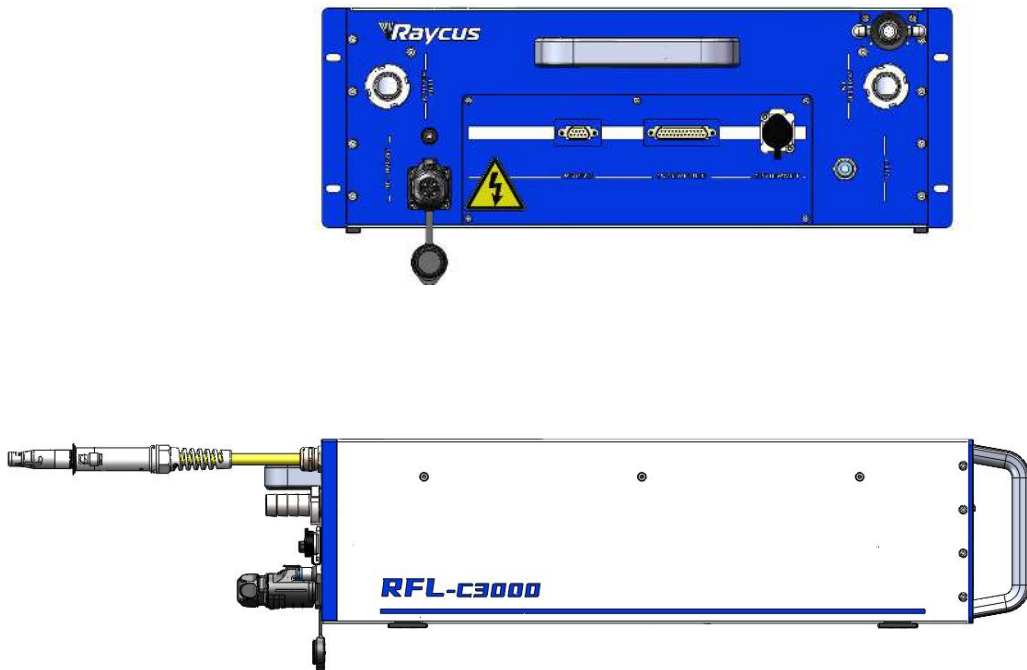

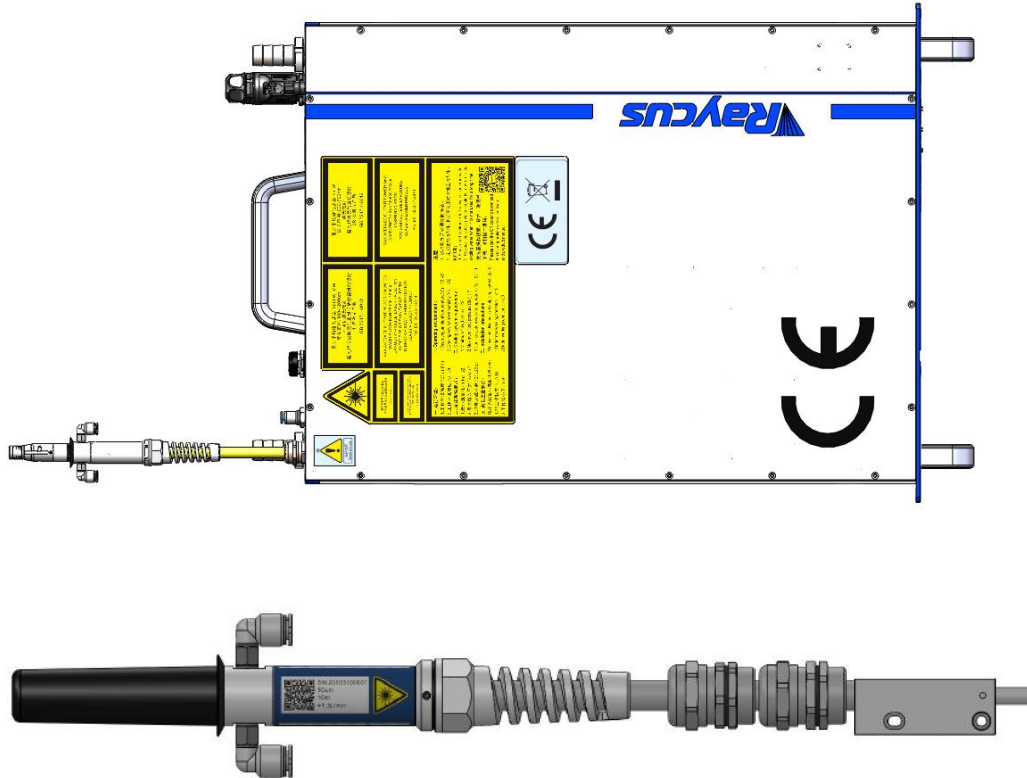





Figure 1: Safety Label Locations of RFL-C3000S-CE

These safety labels include warning labels, apertures through which laser radiation is emitted and labels of certification and identification, etc. Specifications of these labels are as follows:

Table 1: Specifications of Safety Labels

	 <p>(Take 500W for example)</p>	
<p>1. Aperture Label</p>	<p>2. Class 4 Laser Product</p>	<p>3. Class 2M Laser Product Label for Guide Laser</p>

<p>4. CE Compliance</p>	<p>5. Identification Plate</p>	<p>6. Laser Radiation Hazard Label</p>
<p>7. Electrical Hazard</p>		

1.4 Optical Safety

Any dust on the end of the collimator assembly can burn the lens and damage the laser.

	<p>CAUTION: If the output of the device is delivered through a lens with an anti-reflection coating, make sure that the lens is of good quality and clean.</p>
--	---

1.5 Electrical Safety

- a) Make sure your product is grounded through the PE line of the AC power cord. The grounding must be firm and reliable.

	<p>WARNING: Any interruption from the protective earth will electrify the enclosure, which may result in personal injury.</p>
--	--

- b) Make sure that the correct voltage of the AC power source is used.



CAUTION: Failure to connect the correct voltage could damage the product.

1.6 Other Safety Rules

- a) Never look directly into the laser output port when power is supplied to the laser.
- b) Avoid using the laser in a dim or darkened environment.
- c) If this device is used in a manner not specified in this document, the protection provided by the device may be impaired and the warranty will be voided.
- d) There are no operator serviceable parts inside, and all maintenance must be performed in Raycus or by qualified Raycus personnel. Do not try to remove covers, or electrical shock may be caused, and warranty will be void.

2 Product Description

2.1 Features

Compared with traditional lasers, Raycus CW fiber laser has higher efficiency electric-optical conversion, lower power consumption and excellent beam quality. The fiber laser is compact and ready to use. It can be used as a stand-alone unit or easily inserted into user's apparatus.

Main Features:

- Excellent beam quality
- High quality fiber output
- High Power Stability
- Continuously tunable output power, quick switching response
- Maintenance free operation
- High electron-optical efficiency
- Convenient control interface
- High frequency modulation

Applications:

- Cutting, Welding
- 3D Printing
- Scientific research

2.2 Model Configuration

The series of Raycus continuous-wave fiber laser include 1500W and 2000W, and the model designation codes are illustrated in the following table:

Table 2 Model Names and Designation Codes

<p style="text-align: center;"><u>RFL-C 3000S/B/20/W</u></p> <p style="text-align: center;"> 1 2 3 4 5 </p>	
1	RFL-C series, continuous-wave (CW) fiber laser
2	Power in watts: 3000S--3000W
3	Wavelength: B--1080nm
4	Length of delivery cable in meter, including 15m and 20m, and other length can be customized.
5	Cooling method: W-- water cooling A-- air cooling
<p>Note: No air conditioner in this laser series except the RFL-C1500X/C2000X.</p>	

You can find the complete model name on the identification plate.

2.3 Package Contents

Please refer to the packing list accompanying the shipment to check actual items included.

2.4 Unpacking and Inspection

Raycus CW fiber laser is shipped in a package designed to provide maximum protection. Upon delivery, please inspect all packaging for evidence of mishandling or damage. If you find any evidence of mishandling, please save the damaged material and contact the shipping agent and Raycus immediately.

Remove all the contents from the packing case. Take extra care when removing the unit out of the packing case to ensure that the delivery fiber is not twisted, hauled or damaged. A comprehensive packing list is included with the system documentation. Check all items against the list and contact Raycus immediately if there is any missing item or evident damage to the unit. DO NOT attempt to install or operate the laser, if there is any evident or suspected damage to the unit.

It is recommended to keep the packing materials, as they will be necessary if you ever need to ship the unit back for service at a later date.

	<p>CAUTION:The fiber optic cable and output head is precise optic instrument, any vibration or impact to the output head, and twist or excessive bend to the cable will damage the instrument.</p>
---	---

2.5 Operation Environment

The basic operation conditions are listed in the table as below:

Table 3 Basic Operation Conditions for the Laser

Model	RFL-C3000S-CE
Supply Voltage(V)	380 ± 10%V AC 50/60Hz
Supply Capacity(kW)	10
Installation Requirements	Install on flat surface, no vibration or impact
Ambient Temperature(°C)	10~40
Relative Humidity(%)	30~70

Warning:

- a) Ensure reliable grounded before using the laser.
- b) The laser output is connected to the output cable. Please check the laser output carefully to prevent dust or other contamination. Use special paper when cleaning the laser output lens.
- c) If the laser is used in accordance without the method specified in this manual, the laser may be in abnormal working status and cause damage.
- d) It is strictly forbidden to install the laser output when the laser is in operation.
- e) Do not look directly into the laser output. Be sure to wear protective glasses when operating the laser.



- ◆ Do not expose this product to high humidity (>95%)
- ◆ Do not let this product work below the dew point temperature

Table 4 The Constant Dew Point Table

AMBIENT DEW POINT									
Room Temperature (°C)	Maximum Relative humidity								
	20%	30%	40%	50%	60%	70%	80%	90%	95%
20	-3.5	2	6	9	12	14.5	16.5	18	19
25	0.5	6	10.5	14	16.5	19	21	23	24
30	4.6	10.5	15	18.5	21.5	24	26	28	29
35	8.5	15	19.5	23	26	28.5	31	33	34
40	13	20	24	27.5	31	33.5	36	38	39
	Laser operating temperature range								

2.6 Precautions for Use

- a) Before supplying the power to the device, make sure that the correct voltage of the AC power source is used (See Table 3 for the laser model and corresponding input voltage). Failure to connect power source correctly will damage the device;
- b) Failure to follow the instructions may cause malfunction and damage to the device, such damage is not covered by warranty.
- c) It is very important to ensure the cleanness of the calibrated laser output head, otherwise it will cause irreparable damage to the laser.
- d) Please inspect the output head carefully for dust or other contamination. Use appropriate lens paper to clean it if necessary. Do not touch the output lens at any time; as well as remember to cap the output head when it is not in use, and make sure the cap is clean;
- e) Failure to follow the specified instructions may result in the loss of laser power, and such loss will not be covered by the warranty.

2.7 Specifications

The specifications are listed in the following table

Table 5 Specifications

Table 6 Product Specifications Model	RFL-C3000S-CE	Test Conditions
Optical Specifications		
Nominal Output Power (W)	3000	
Operation Modes	CW/Modulated	
Polarization State	Random	
Power Adjust Range(%)	10~100	
Emission Wavelength(nm)	1080±5	Nominal Output Power
Output Power Instability(%)	±1.5	Nominal Output Power
		Operation Time: ≥5h
		Ambient Temperature: 22±1℃
Modulation Frequency(Hz)	1~5,000	Nominal Output Power
Red Guide Laser Power(mW)	0.5~1	
Optical Output Characteristics of QBH head		
Beam Quality(mm×mrad)	1.5~2	Nominal Output Power
Fiber Core Diameter(μm)	50 (with 100、200 options)	
Numerical Aperture	0.2	
Delivery Cable Length(m)	20	Length customizable
Electrical Characteristics		
Power Supply	380±10% V AC、50/60Hz	
Max. Power Consumption(W)	10000	
Control Mode	RS-232/AD/Ethernet	
Other Characteristics		
Dimensions(W×H×D) (mm)	485*172*727 (include. handles)	
Weight(kg)	<55	
Operating Ambient Temperature (℃)	10~40	
Humidity (%)	30~70	
Storage Temperature (℃)	-10~60	
Cooling Method	Water Cooling	

3 Installation

3.1 Dimensions

Figure 2 shows dimensions of RFL-C3000S-CE.

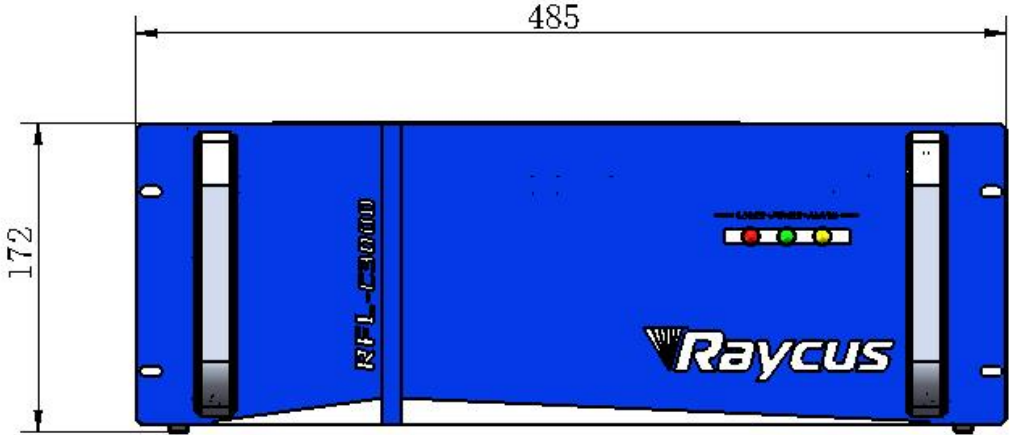

Figure 2 (a) Front panel view of RFL-C3000S-CE(unit: mm)

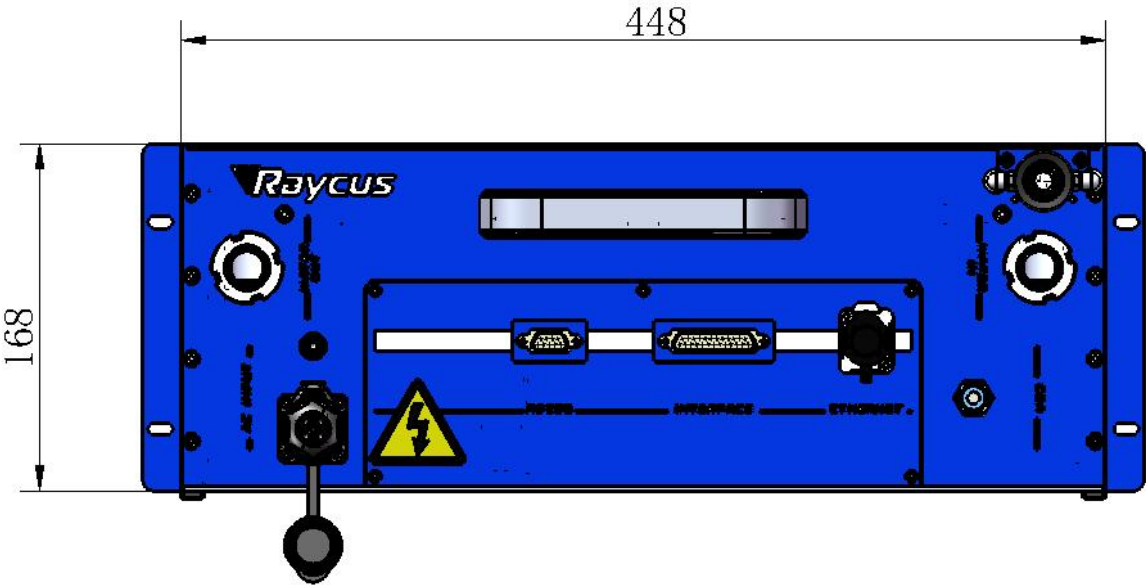

Figure2 (b) Rear panel view of RFL-C3000S-CE (unit: mm)

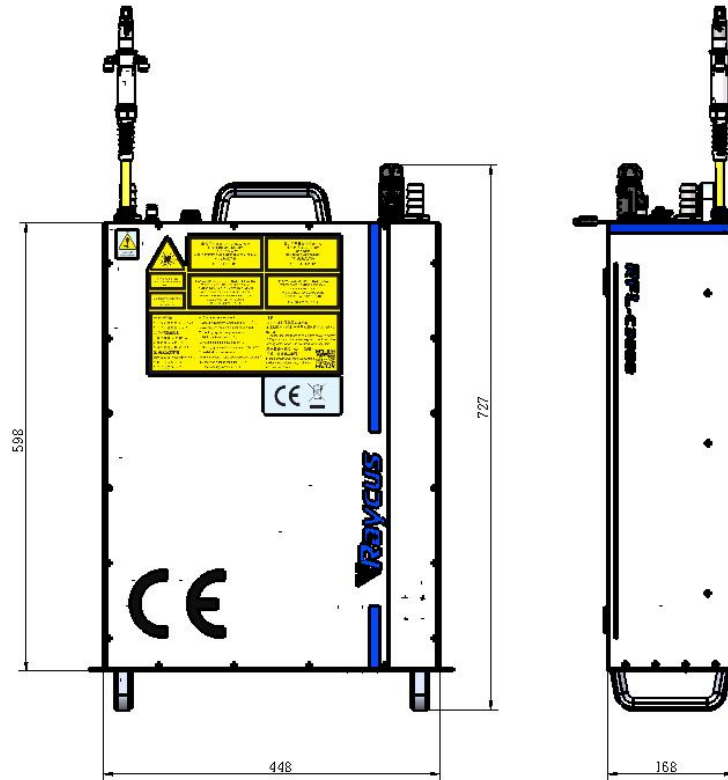

Figure2 (c) Top and Side view of RFL-C3000S-CE (unit: mm)

3.2 Output Head and Installation

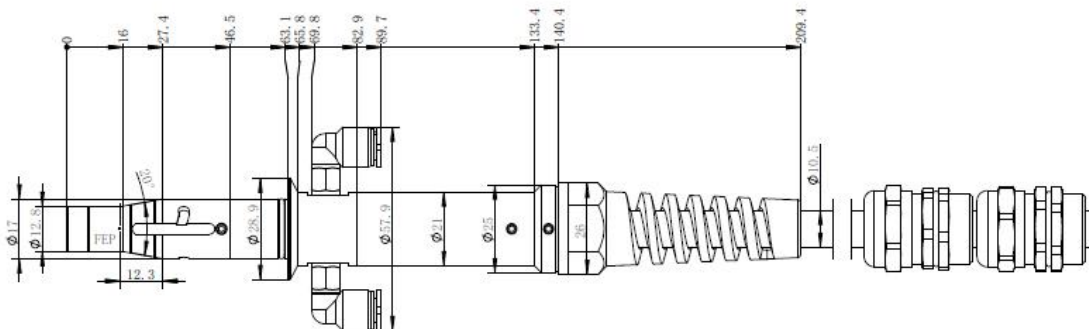

Figure 3B Dimensions of iQB Output Head

The QBH and iQB laser output head of RFL-C3000S-CE are all the standard IQB interface. The specific appearance and dimensions are shown in Figure 3 above.

**CAUTIONS:**

- ◆ Inspect the output lens before installing the output head to the processing head. Clean the output lens if necessary.
- ◆ It is strictly prohibited to disassemble the output head by personnel not approved by Raycus, or the warranty is void.

3.3 Cooling Requirements

Table 6 Cooling Requirements

Model	RFL-C3000S-CE
Cooling Capability(W)	>7500
Minimum Flow(L/min)	22
Maximum Pressure(Bar)	7
Pipe Inner Diameter(mm)	19
Water temperature of coolingsystem(°C)	22 ± 1 °C

- a) The water temperature setting of cooling system:
22 ± 1 °C (RFL-C3000S-CE)
- b) Cooling water requirements:
 - It is recommended to use purified water.
 - In order to prevent mould growing that may lead to pipe blockage, we recommend to add alcohol about 10% of the total volume.
 - If the product is used in an environment that ambient temperature is between -10 °C and 0 °C, we recommend to use 30% alcohol, and replace it every two months.
 - If the product is used in an environment that ambient temperature is below -10 °C, please use dual-system chillers (with heating function) and ensure uninterrupted operation of the cooling system.
- c) Requirements for output cable cooling system:
 - Rate of liquid flow: 1.7-2.0 L/min;
 - Pressure of liquid flow: < 0.6 MPa at the inflow;
 - Type of liquid exchange junction: SMC MS-5H-6;
 - Type of tube: outer diameter 6; inner diameter 4;

- Direction of cooling liquid: unidirectional; connect the tube with the water-pipe strictly according to direction shown on the layer of the tube;
 - Type of liquid: deionized water, condensed water, pure water;
 - PH value of liquid: 5.5 - 9;
 - Filter is needed for the cooling system, and the size of the solid residual practicals should be within 100um;
 - Maximum temperature of liquid: 45°C;
 - Minimum temperature of liquid: greater than the saturated dew-point 5°C;
 - Additive to the liquid: satisfies the requirements of PH value and size of solid residual practicals as above;
 - Radius of the bending of the armored pipe: off-work state (i.e. transportation and reservation): minimum radius of bending ≥ 20 cm; in-work state: minimum radius of bending ≥ 30 cm;
 - Long-term vibration < 2 G; Impact action < 10 G.
- d) Other requirements for chiller:
- When starting the cooling system for the first time, check the entire water system and the joint for water leakage. The external water pipe must be installed and connected according to the inlet (IN) and outlet (OUT) by the laser. Otherwise, the laser may not work properly.
 - If you will not use the laser for a long time, water must be emptied from the product, and then both the inlet and outlet must be blocked with the nuts we provide. Failure to do so may lead to permanent equipment damage.



CAUTION: Please set the water temperature in strictly accordance with the requirements above. Too low temperature may lead to condensation on the laser module and the output cable. This can cause serious damage to the equipment.



CAUTION: Make sure that the water temperature reaches the set point and the cooling system is working well before you start the laser.

〔**summer:** $22 \pm 1^\circ\text{C}$ (RFL-C3000S-CE) ; **winter:** $22 \pm 1^\circ\text{C}$ 〕

3.4 Installation Procedure

- a) Place the product in a still and stable position;
- b) Check if the power supply has the correct voltage (See Table 5 for the laser model and corresponding input voltage), and the earth line is connected, make sure it is firm and reliable;
- c) Connect the power cable and control cable to the product when power supply is OFF;
- d) Insert the water pipes into the inlet and outlet port;
- e) Check the output head and clean it if necessary. This procedure must be performed by personnel of Raycus or authorized by Raycus. Make sure the environment is clean, or the output cable may be contaminated.
- f) Prevent the delivery cable from treading, pinching or excessive bending during installation;
- g) During the installation and dis-assembly process, please take care to handle the laser output head gently, avoiding any shock;
- h) In the installation of laser output cable and output head process, please make sure that the surrounding environment is clean, otherwise it may pollute the output head (do not use fans, which actually may bring more dust);
- i) The minimum bending radius of the output fiber cable of the laser should not be less than 20 cm under the non-working conditions, and the minimum bending radius should not be less than 30 cm when the laser is working.



CAUTION:

- ◆ All the cables can only be connected when power supply is OFF. Hot plug may damage the laser.

	<p>CAUTION:</p> <ul style="list-style-type: none">◆ The laser output optical cable should be kept as natural as possible and not be distorted.◆ The too small bending radius of the output fiber cable will damage the laser.
---	---

	<p>CAUTION:</p> <ul style="list-style-type: none">◆ Make sure the aperture and the cavity of the processing head is clean;◆ Keep the protective cap properly, prevent it from contamination; Or the aperture will be contaminated when capped.
---	--

4 Using the Product



Raycus CW fiber laser has stopped using the HyperTerminal, so the HyperTerminal will not work when the laser is powered on. Please click the address below to download the latest PC software and the relevant manual.

4.1 Front Panel

Figure 4 shows the front panel of RFL-C3000S-CE (take RFL-C2000 for example):

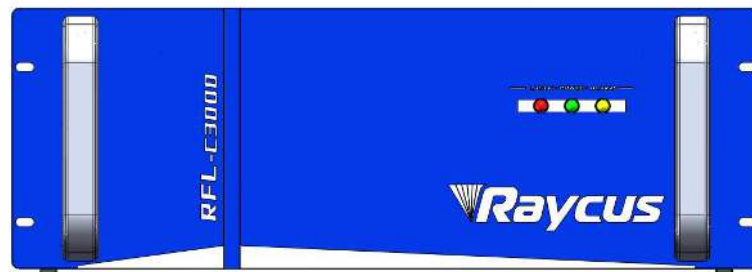

Figure 4 Front Panel of RFL-C3000S-CE

1. **POWER:** Control system power indicator light, when the red light is on, it means that the laser is powered on.
2. **LASER:** The laser is emitting light normally. When the green light is on, it means that the laser is emitting light.
3. **ALARM:** Alarm indication, when the yellow light is on, it means that the machine has an alarm.

4.2 Rear Panel

Figure shows the rear panel of RFL-C3000S-CE:

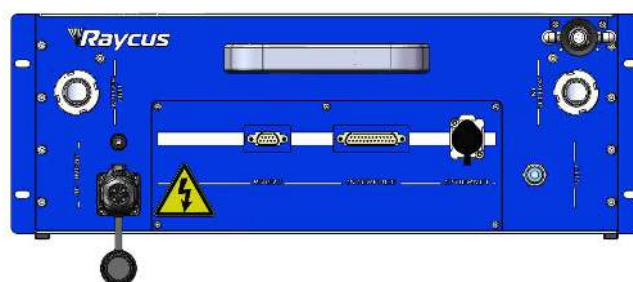

Figure 5 Front Panel of RFL-C3000S-CE

1. **AC INPUT:** The socket for supply source input that can only be mated with the plug on the power cord we provided (See Table 4 product technical parameters for laser model and corresponding input voltage). Please use only the enclosed power cord provided by Raycus.
2. **CTRL-INTERFACE:** Control interface, CTRL-INTERFACE interface (DB-25), multi-function multiplex interface, users can set control mode, input analog voltage signal, modulate 24V signal, and it is also an alarm signal output interface.
3. **RS232:** Provide remote control and fault information storage of the laser.
4. **WATER:** Pipe connectors, the inlet and outlet for cooling water to flow in and return. (See Table 5 for the laser model and corresponding water pipe size for cooling system requirements)
5. **ETHERNET:** Ethernet interface. It can provide remote control and storage alarm information for the laser.
6. **CDA:** Dry air inlet.

4.3 Power Connection



	<p>CAUTION: Before connecting the product to AC supply source, you must check for sure that the AC supply you will apply is in accordance with the specifications provided in Table 3 or Table 5.</p>
---	--

Table 7 Power Connection Requirements

Model	RFL-C3000S-CE
Supply Source	380±10% V AC 50/60Hz

Power Cord	
One End of Power Cord	Four wires labeled L1, L2, L3 and PE.
Sign Description	L1, L2, L3-> Phase Line PE-> Protective Earth
Note	One end of the power cord is a plug, insert it into the socket 'AC INPUT' on the rear panel. Notice that the plug is wrong-side preventing. After inserting it, lock it with the lever.

4.4 Interface Definitions

4.4.1 CTRL-INTERFACE Definitions

The CTRL-INTERFACE(DB-25) is for laser control, the designation and definition is below:

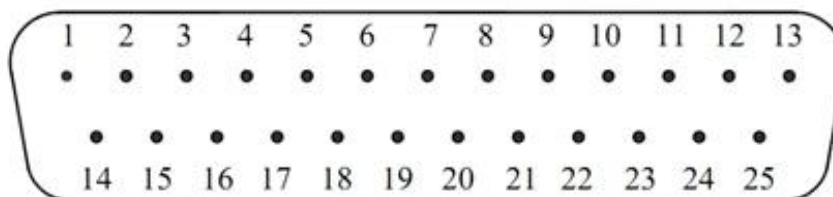

Figure 8 Diagram of CTRL-INTERFACE

Table 7 Definitions of 24 pin Ctrl Interface

PI N	Name	LineMark	Type	Level	Drive Current	Typical Respon	Description
---------	------	----------	------	-------	------------------	-------------------	-------------

No						se Time	
1	Interlock1A	ITL-1A	Contact Closure Input	24Vdc	<10mA	<500ms	“EN954-1” or”ISO13849-1 Cat.3PLd”. Passive contact, not connected to external voltage or grounding.
2	Interlock2A	ITL-2A					
3	Interlock2B	ITL-2B					
4	Interlock1B	ITL-1B					
5	NC						
6	NC						
7	NC						
8	Remote Key Switch	RPA	Contact Closure Input	24Vdc	---	20s	Activates the internal control system power supply in REM mode. Passive contact, not connected to external voltage or grounding.
9		RPB					
10	Remote Start Button	START-A	Instantaneous Contact Closure Input	24Vdc	---	1s	In REM mode, start the laser main power supply. Passive contact, not connected to external voltage or grounding.
11		START-B					
12	Analog Input to Control Current	1-10V	Analog Input	1-10 Vdc	10 mA	100μs	Analog Input 1-10 VDC= 10 – 100% Setpoint
13	Analog Output Power Monitor	AOUT	Analog Output	0-8.0 Vdc	>5mA	20μs	Analog Output 0-8VDC (Refer to factory inspection report for details)
14	Isolated Analog Com	AGND	Return	---	---	---	Return for signals on pins 12, 13
15	Modulation+	MOD+	Digital Input	24VdC	<10 mA	20μs	24 VDC Input
16	Modulation-	MOD-	Return	---	---	---	Return for signal on pin 15
17	Guided Laser Control	RED-LASER	Digital Input	5-24Vdc	<10 mA	120ms	Positive edge activates emission in REM mode

18	Emission Enable	LAS-C	Digital Input	5-24VdC	<10 mA	120ms	Positive edge activates emission in REM mode
19	READY	READY	Digital output	24VdC	> 10mA	120ms	High=Laser is ready
20	System Common	GND2	Return	---	---	---	Return for pin 17/18/19/21/22/23/24
21	Error RESET	RESET	Digital Input	5-24VdC	<10 mA	120ms	Rising edge reset (the resettable alarm)
22	Laser Alarm	S-ERR	Digital output	24VdC	> 10mA	120ms	High=Alarm status
23	Power started	POWER	Digital output	24VdC	> 10mA	120ms	High= The main power supply is started
24	Laser emission	LASER	Digital output	24VdC	>10mA	100ms	High=Laser is emission



◆ Caution: Please check the control voltage level and ensure that the level is in accordance with the requirements. Over voltage and voltage ripple may damage the product.

The Service Security Interface is pin 1-4 and pin 2-3, of CTRL-INTERFACE. If the pin 2-3 and pin 1-4 are disconnected, the laser will immediately stop emitting light, and the laser Ready signal output will change to low level. Be sure to short-circuit pin 2-3 and pin 1-4 before using the laser. If it is not short-circuited, the laser will display InterLock alarm after power-on.



◆ Interlock interface must not be connected to active signal, otherwise it will cause interface damage and laser alarm.

4.4.2 TCP/IP Interface Configuration

The default IP address of this product is 192.168.0.10, only supporting UDP communication. The laser listens for connection on port is 8098, and the command must be sent in a single data string.

Table 8 The pin definitions of Ethernet interface

PIN	FUNCTION	DESCRIPTION
1	TX+	TRANSMIT+
2	TX-	TRANSMIT-

3	RX+	RECEIVE+
4	N/C	NONE
5	N/C	NONE
6	RX-	RECEIVE-
7	N/C	NONE
8	N/C	NONE

For better communication stability, recommend to use this interface first.

Table 9 The default IP address of the laser

The default IP address of the laser	
IP address	192.168.0.10
Subnet mask	255.255.255.0

Steps of Ethernet connection:

- a) Open "Local Connection" on your computer, and then click "property";
- b) Select "Internet Protocol Version 4 (TCP/IP 4);
- c) Click the "Property";
- d) Check "Use the following IP address:" to manually assign an IP address;
- e) Manually assign an IP address is 192.168.0. x (x cannot be 10, because 192.168.0.10 has been assigned to the laser) , and assign a subnet mask address. The default is 255.255.255.0;
- f) Click the "OK" button to confirm the settings and exit. The IP address is different from the default gateway, see Figure 9.

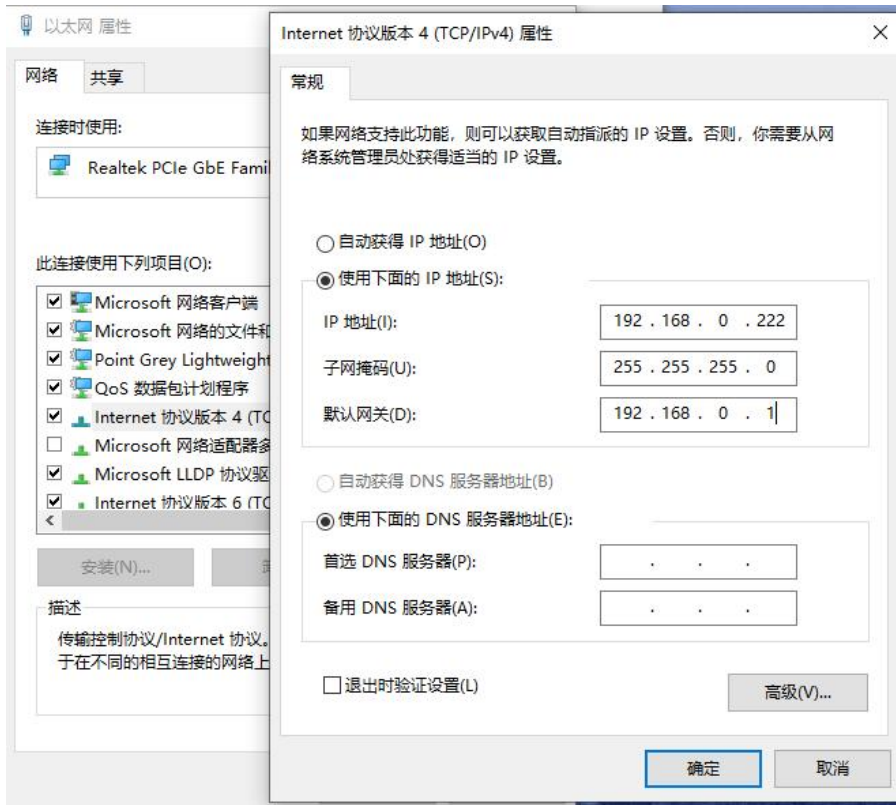

Figure 9 Steps of Ethernet Connection

When the IP setting is completed, turn on the host computer, and the connection status in the corresponding text box on the host computer interface displays: connected, indicating that the microcontroller program is running normally and the communication connection is normal. The display interface is shown in Figure 10 below.



Figure 10 The main interface is displayed when the communication connection is normal

4.5 Steps of Installation

- a) Carefully takeout the laser from the box and move it to the installing position and then lock the casters;
- b) Remove the output cable protective cap and check the output lens for dust with strong light and clean it if necessary, then cover the output cable protective cap;
- c) Install the output cable on the processing equipment according to the actual situation (install the output head cooling water pipe at the same time), pay attention to the output cable and head,then remove the protective cap andconfirm that the output lens is clean and install the output head;
- d) Connect cooling water pipe;
- e) Connect the control line and power according to the control mode.

4.6 Steps of Starting

It is determined that the air switch is disconnected, and all electrical connections must be completed before the laser is powered on;

- a) Make sure that the pins the 24-pin are closed;
- b) Turn on the chiller and check leakage. If there is no water leakage, turn off the chiller and wait for the laser to turn on;
- c) Turn on the air switch ;

4.7 Functions of the clientware

The RFL-C3000S-CE clientware communicates with the main control board through UDP when it is working. Through the background program running in the software and the human-computer interaction operation, the laser parameters are read and set and the control functions are realized. The interface displayed by the software is divided according to functional categories, including control, alarm, about, language selection, authorization, working mode selection and other pages.



Figure 11 The clientware interface

4.7.1 The control interface

The control interface is the content displayed on the first page after opening the clientware, including the user's most commonly used status signal, laser parameter setting and laser control related functions.

Control abnormal laser reset: Click the reset button to run the abnormal laser reset command.

Guide laser: the guide laser is turned on or off in the internal control state of guide laser. After the guide laser is turned on or off, there will be changes in the guide laser state on the software.

Guide laser external control: turn on the guide laser external control or turn off the guide laser external control. After turning on and turn off the guide laser external control, there will be changes of the guide laser external control state in the software. If the current red external control state, then disable the red control button.

Control laser parameters: Optical output parameters include power, frequency, pulse width, and duty cycle. The communication between the software and the main control board requires only power, frequency, and pulse width. The duty cycle can be calculated from the pulse width and frequency, and the pulse width can also be calculated from the duty cycle and frequency. During the software operation, the frequency and duty cycle will be changed synchronously with the pulse width, and the duty cycle will also be changed synchronously with the frequency and duty cycle. The output power can be an integer in the range of [0,100]. The frequency can be set to a decimal in the range of [0,20000]. The duty cycle can be set to a decimal in the range of [0,100].

Control light emission mode: light emission related modes include AD mode, external enable, external modulation mode, and internal modulation mode. You can individually control the opening and closing of each mode, and display the current status of each mode. After the AD mode is turned on, the optical power is controlled by an external signal, and the power setting function of the software should be set to a disabled state. When the external modulation mode is turned on, the frequency, pulse width and duty cycle are controlled by the external modulation signal, and the function of the software to set the frequency, pulse width and duty cycle should be set to the disabled state.

Control the light: control to turn on or off the laser emission or laser enable. Only when the laser has a ready signal, can it be controlled normally, otherwise the buttons for turning on and off the laser are set to the disabled state. When the external control light enable is turned off, and the external modulation mode or internal modulation mode is turned on, the "laser enable" is displayed, otherwise, the "laser emission" is displayed.

Status display: Including emergency stop, laser enable, Interlock logic normal, Interlock1 closed, Interlock2 closed, power ramp up and down, program mode, program execution, program execution completed, program execution abnormal and other most commonly used laser states, and machine Internal ambient temperature, internal ambient humidity, dew point, external 0-10V,

light output frequency, light output duty cycle, light pulse width, laser water flow, output optical cable water flow and other data. These status and data refresh time intervals should not exceed 300ms.

Laser usage time display: including today's turn-on time, today's light-emitting time, cumulative turn-on time, and cumulative light-emitting time.

4.7.2 The alarm interface

All the alarm information of the current laser is displayed on the alarm interface, and the alarm information is updated in real time.



Figure 12 The alarm interface

4.7.3 About

The laser time, model, serial number, master control serial number, key version number and system information are displayed in the interface, when the about interface is opened, the upper computer software reads them from the master control module once.



Figure 13 The about interface

4.7.4 Language Selection

In the language selection interface, you can set the language used by the software. After selecting the language and clicking OK, you do not need to restart the software, automatically convert the content displayed in the software into a language, save the currently selected language to the configuration file, and display it according to the last set language when starting the software next time.



Figure 14 Language selection interface

4.7.5 Authorization

The authorization interface is used to control the limited time lock of the laser, when the authorization interface is opened, the machine code, laser lock time and lock time are loaded once, the laser lock time is Raycus's limited time lock for integrators, and the lock time is for the integrator to end customers. Limited time lock. In the authorization interface, only Raycus' authorization code can be set, and the function of calculating the authorization code is implemented in the server and has nothing to do with the host computer software. The authorization code used by the integrator can be generated in the authorization interface.

Figure 15 Authorization interface

4.7.6 The Mode Selection function

Select the operating mode of the software, including monitor mode, control mode, diagnostic mode, and debug mode.

Monitor mode: **The monitor mode is selected by default when the software is opened.** The most commonly used and concerned information is displayed on the software interface to avoid the interference of too much information to the user. The monitor mode can be used without password.

Control mode: The control mode adds the function of the operable control interface on the basis of the observation mode, and the password is required to enter the control mode.

Debug mode: On the basis of diagnostic mode, the parameter setting interface is added. Only Raycus debug engineers can enter the encryption mode.

Diagnostic mode: When a laser fails to diagnose remote after -sales, or the integrated dealer needs to understand more status information of the laser, you can enter the diagnostic mode.

4.7.7 Main control module

The main control module contains all states, alarms and system parameters of the main control module. The status and alarm information are automatically refreshed. Only when the currently selected page is in the main control module, the upper machine software will automatically read and refresh status and alarm information information information. , Reduce the frequency of communication and avoid too many resources to occupy the main control module.



Figure 16 Main control module status information interface

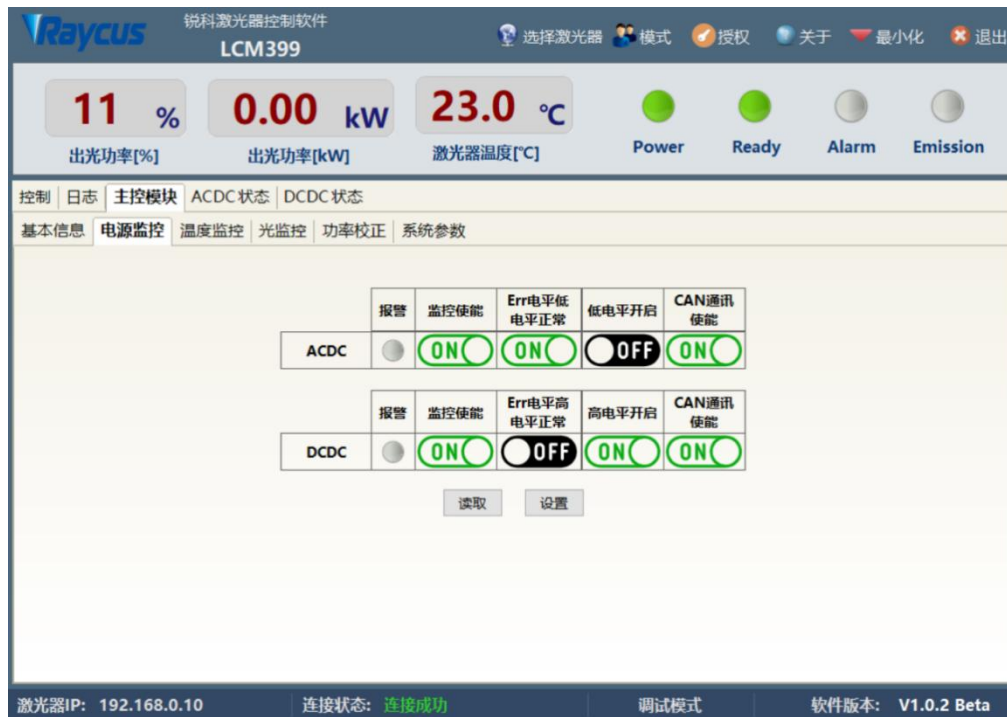

Figure 17 Alarm information interface of main control module

4.7.8 Slave control module

Power surveillance contains the alarm of the ACDC module and DCDC module. The monitoring enables the control, the failure level is high, the low level is set, the level is high, low settings, and the CAN communication enables the settings.



Figure 18 Slave control module status information interface

4.8 Control Modes

The laser selects AD mode, external control, internal modulation mode and external modulation mode through the upper machine interface.

4.8.1 Control mode wiring diagram

4.8.2.1 Internal control mode

Figure 19 Internal control wiring diagram mode

Operation method:

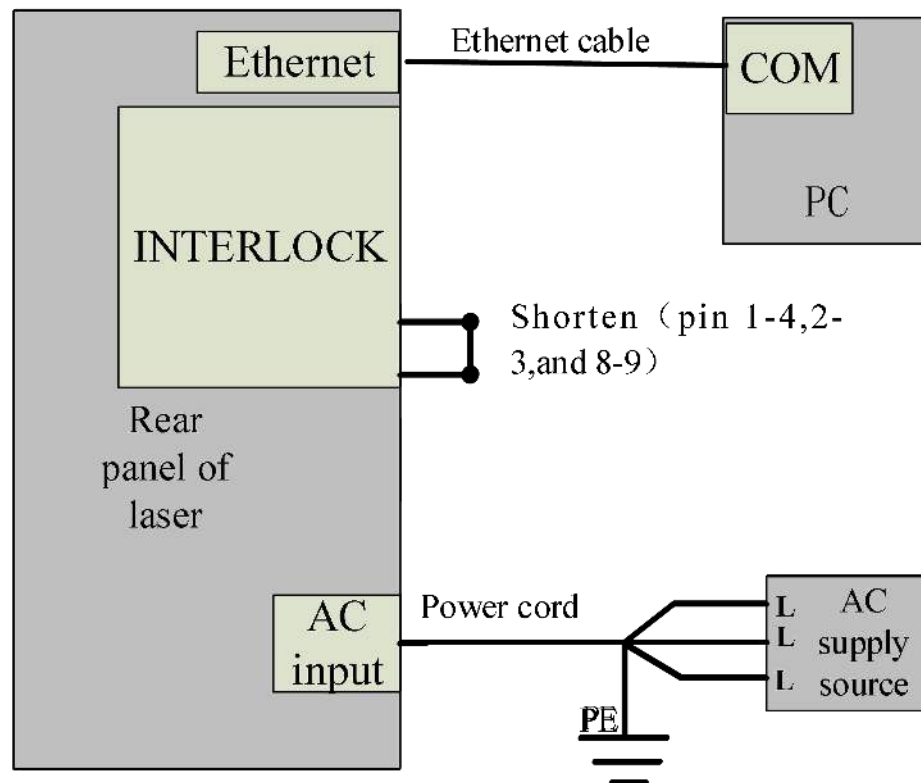

- Short connection of 8, 9 pin on the 24 -pin of 24 stitches (power on the control board);
- Open the air, the panel "POWER" indicator lights;
- Open the upper machine software and close all the external mode (turn off the red light external control, external envelopes, external AD and external modulation);
- Click the red light button to view the red light;

- e) Set out the light parameter;
- f) Click “laser ON”.

4.8.2.2 Internal/external modulation modes for power and communication

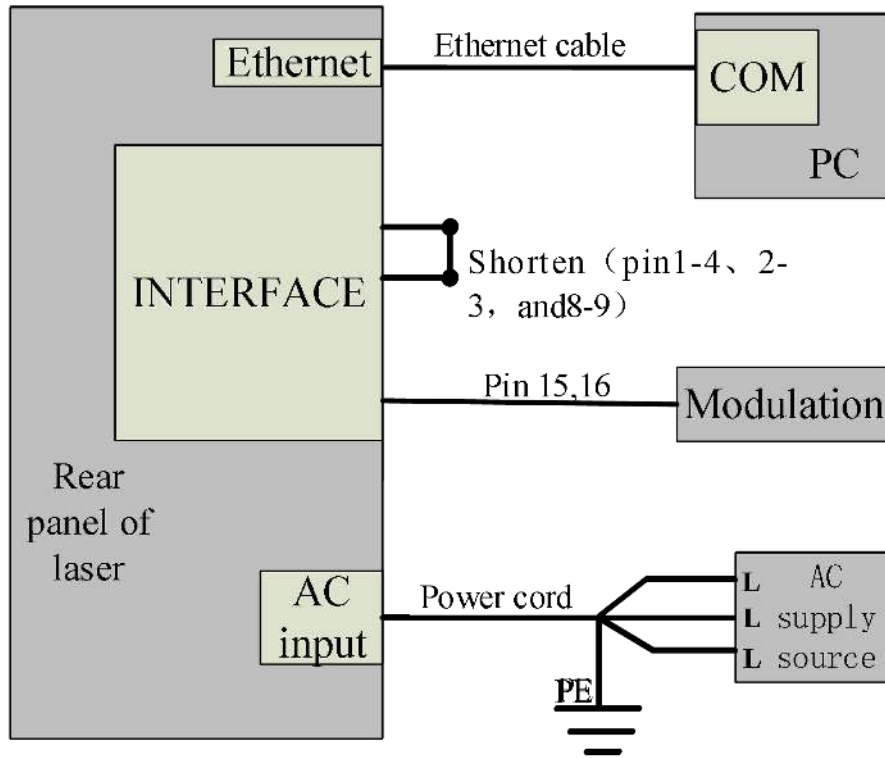

Figure 20 Wiring diagram of internal power control and external signal control

Operation method:

- a) Shortconnect the 8 and 9 pins on the INTERFACE 24 pins (the control board is powered on);
- b) Open the laser clientware;
- c) Click “the guide laser ON” button to view the guide laser;
- d) Disabling the AD mode and the external envelopes。
- e) Waiting “Ready”;
- f) Setting laser power parameters;

- g) When the duty cycle of the internal output frequency of the laser is set, set the output frequency/duty cycle/pulse width; (the output light is determined by the modulation signal of pin 15.16 and the output frequency and duty cycle set by the upper computer software); the internal output frequency of the laser is not required When the duty cycle is used, the default setting parameters are that the frequency is 100Hz and the duty cycle is 100%.
- h) Modulation signal (15, and 16-pin) provide a high level to turn on the laser.

4.8.2.3 Power communication setting parameters in the external control mode, external modulation, external envelopes

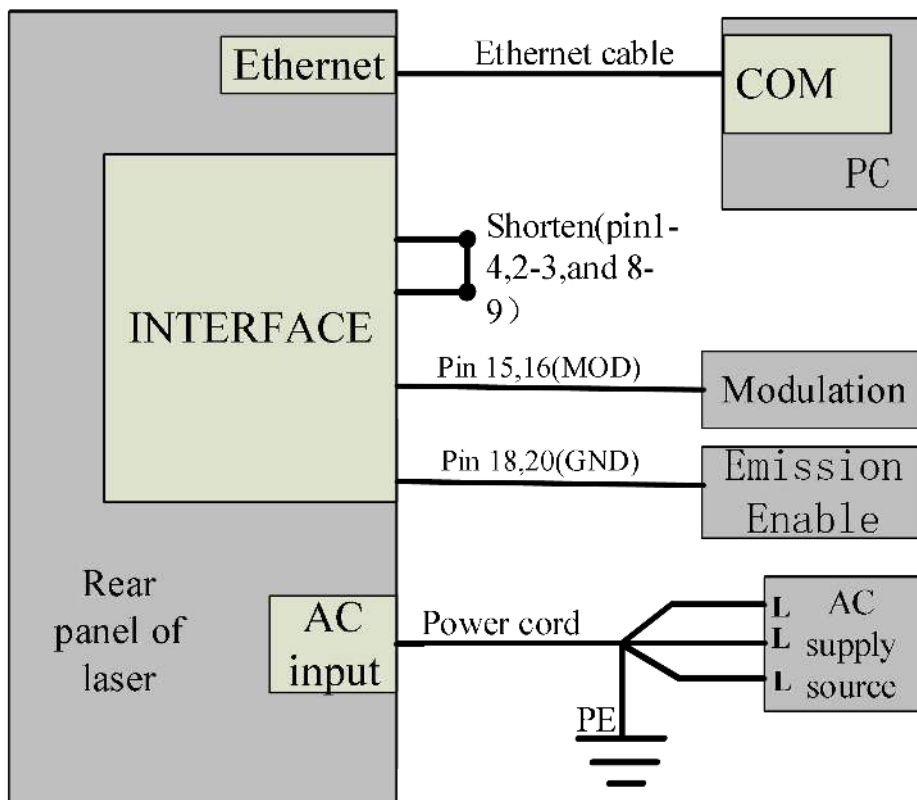

Figure 21 In the external control mode, the power internal control, out -of -light external control, and the external enable wiring chart

Operation method:

- a) Shortconnect the 8 and 9 pins on the INTERFACE 24 pins (the control board is powered on);
- b) Open the laser clientware;

- c) Click “the guide laser ON” button to view the guide laser;
- d) Turn off the AD mode, and opening external enable mode 、 external modulation mode;
- e) Waiting “Ready”;
- f) Interface 24 stitches on 18 pins input rising edges;
- g) Setting laser power parameters;
- h) When the internal output frequency occupation ratio of the laser is required, set out the light frequency/duty cycle/pulse width; (out of the output of the light and the output of the output of the 15.16 -pin and the output ratio of the upper machine software); no internal output inside the laser is required When the frequency occupation ratio, the default setting parameter is 100Hz and the duty cycle is 100%.
- i) 15, 16 -foot adjustment signal output high level to turn on laser.

4.8.2.4 In the external control mode, the power simulation amount is set in external settings, external modulation mode, internal control enable enable

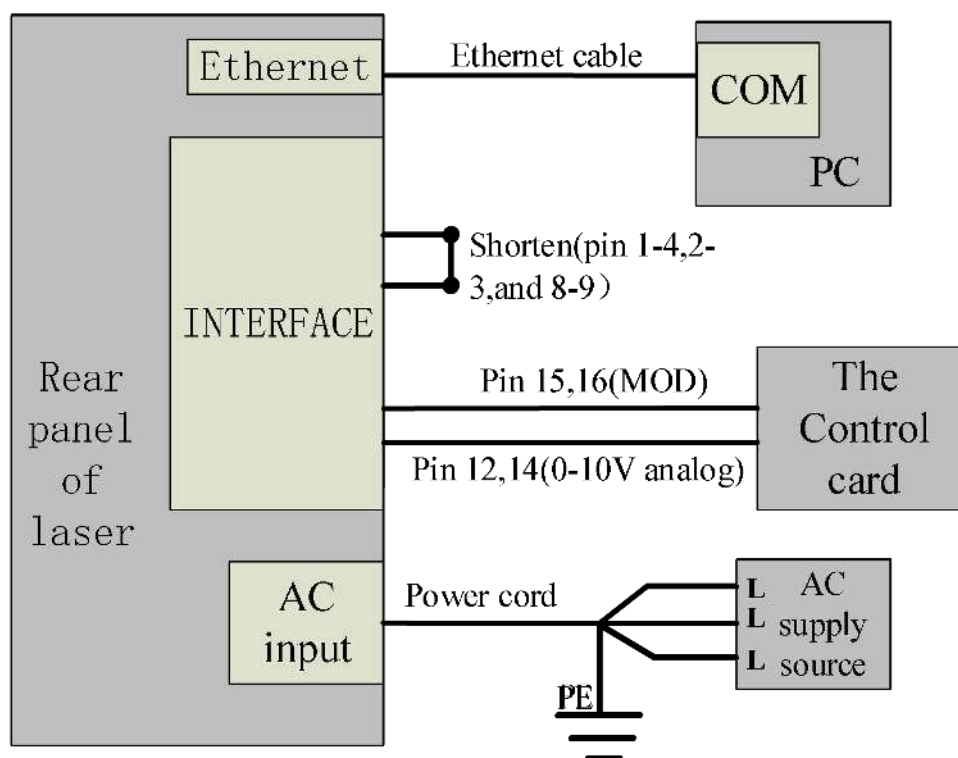

Figure 22 In the external control mode, the power and light are all external control wiring diagrams

Operation method:

- j) Shortconnect the 8 and 9 pins on the INTERFACE 24 pins (the control board is powered on);
- k) Open the laser clientware;
- l) Click “the guide laser ON” button to view the guide laser;
- m) Open the AD mode、 external modulation mode, turn off the external enable.
- n) Waiting “Ready”;
- o) When the internal output frequency occupation ratio of the laser, set out the light frequency/duty cycle/pulse width; (out of the output of the light and the output ratio of the upper machine software set by the 15.16 -footed signal and the upper machine software); the internal output frequency of the laser is required for At the time of occupation ratio, the default setting parameter is 100Hz, and the duty cycle is 100%;
- p) Control board card output analog (12, 14 pin) and outlet signals (15, 16 pin).

4.8.2.5 In the external control mode, the power simulation amount is set in external settings, external modulation mode, external enable

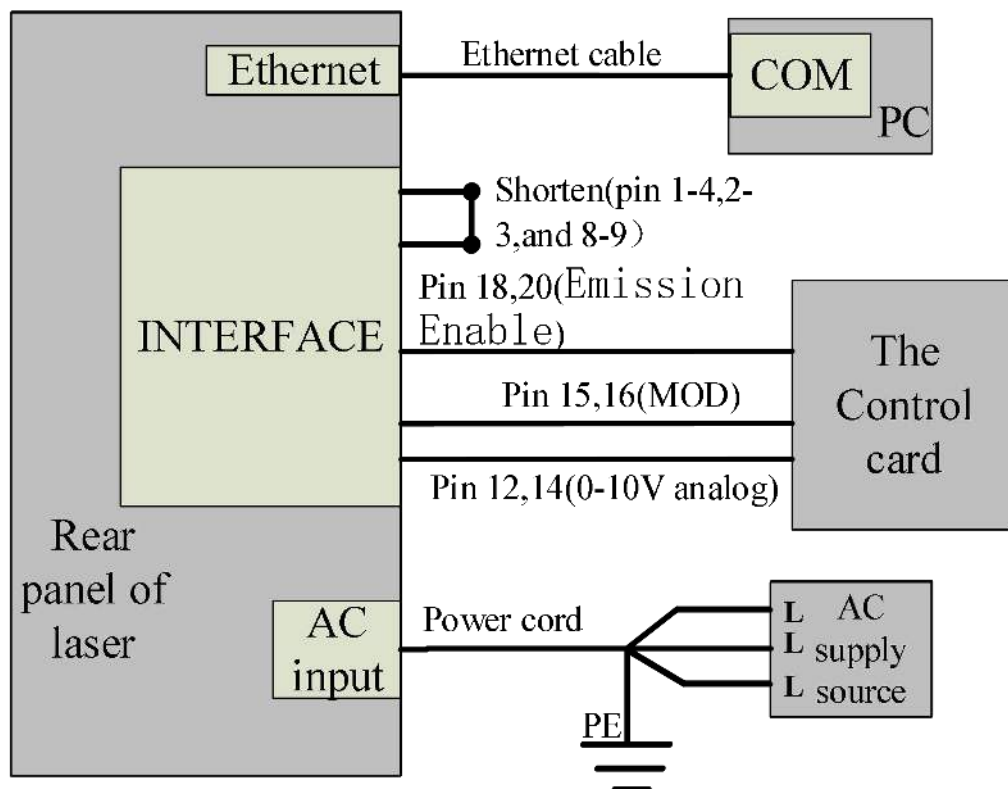

Figure23 In the external control mode, the power, light, and enable all control wiring diagrams

Operation method:

- q) Shortconnect the 8 and 9 pins on the INTERFACE 24 pins (the control board is powered on);
- r) Open the laser clientware;
- s) Click “the guide laser ON” button to view the guide laser;
- t) Open the AD mode, the external enable, the external modulation mode;
- u) On Click on the main power ON;
- v) Waiting “Ready”;
- w) Interface 24 stitches on 18 pin input rising edges;
- x) When the internal output frequency occupation ratio of the laser is required, set out the light frequency/duty cycle/pulse width; (out of the output of the light and the output of the output of the 15.16 -pin and the output ratio of the upper machine software); no internal output inside the laser is required When the frequency occupation ratio, the default setting parameter is 100Hz and the duty cycle is 100%.
- y) Control board card output analog (12, 14 pin) and outlet signals (15, 16 pin).

4.8.2.6 Modification mode and Gate mode

Modification mode: When the duty cycle of the internal frequency of the laser is set to 100%, the laser works in the external modulation mode.

Gate mode: When the duty occupation ratio of the internal frequency of the laser is less than 100%, the laser works in the internal modulation mode. Stop the internal pulse occurring;

4.9 Guide laser control

Table10Guide laser control

Guide lasercontrol	
ON	17 pin of INTERFACE Rising edge -- turns on guide laser; Fallingedge -- turns on guide laser.
OFF	The clientware: Red ON -- turns ON guide laser;

Red OFF -- Turns OFF guide laser.

4.10 The Programming Mode (Waveform Editing)

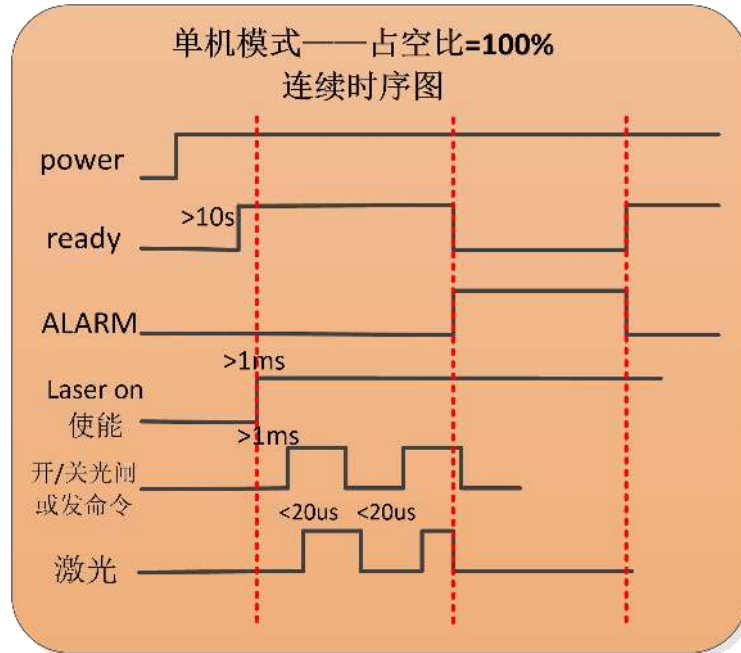

Figure24 Single -machine mode -continuous control time sequence diagram

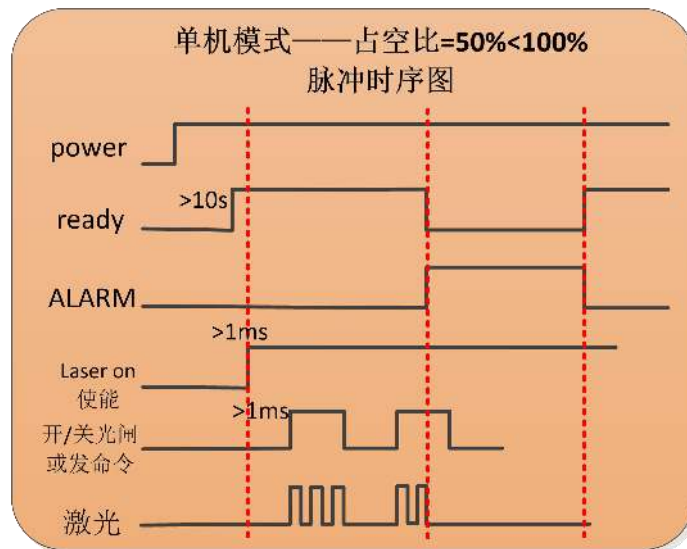

Figure25 Single -machine mode -pulse control time sequence diagram

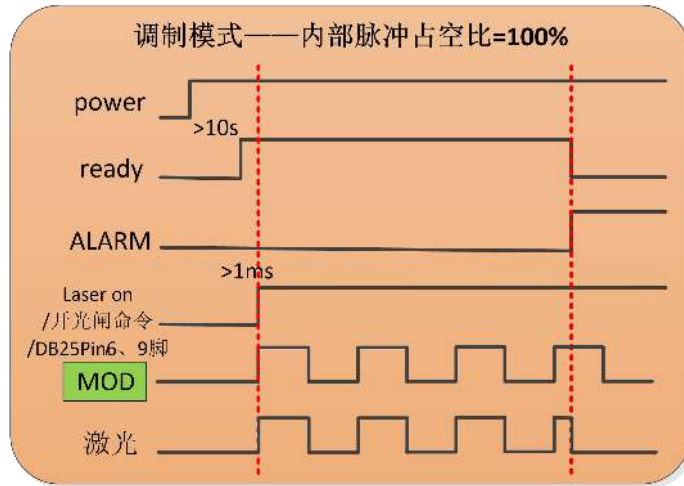

Figure26 Modify mode control time preface diagram

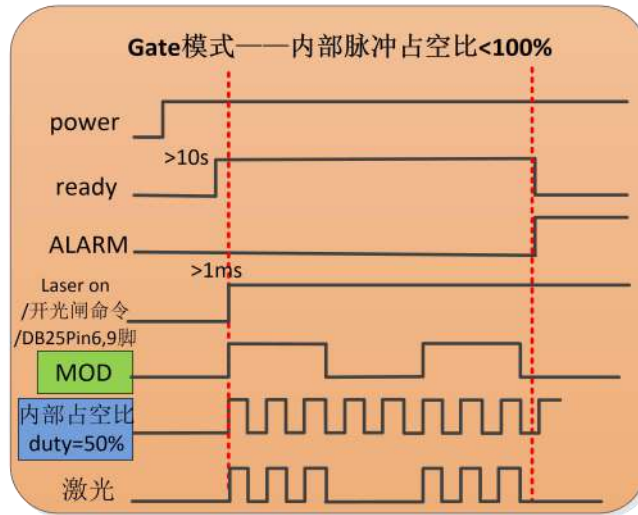

Figure27 Gate mode control time sequential chart

4.11 Modulation signal requirements

The modulation frequency range of the RFL-C3000S-CE laser is 1-20000Hz, and the minimum pulse width of the laser must be greater than or equal to 160μs, reference value of laser frequency and duty cycle setting is shown in Table 11.

Table11 Reference value of the frequency and duty occupation ratio of laser

Frequency	95%	90%	80%	70%	65%	60%	55%	50%	45%	40%	35%	30%	25%	20%	15%	10%
5000Hz	190μs	180μs	160μs													
4500Hz		200μs	177μs													

4000Hz			200μs	175μs	162μs												
3500Hz				200μs	185μs	170μs											
3000Hz						200μs	183μs	166μs									
2500Hz								200μs	180μs	160μs							
2000Hz									200μs	175μs							
1500Hz											200μs	166μs					
1000Hz													200μs				
500Hz															300μs	200μs	

4.12 Steps of shutting down

Please turn off the laser in the order below:

- a) Turn off the emission;
- b) Disconnect the air switch;
- c) Turn off the cold water machine;
- d) Cover the output head protection cap;

4.13 Bluetooth app operation description

4.13.1 Log in

After opening the single -mode laser app, there is an account password login page, as shown in Figure 28:



Figure28 login interface

4.13.2 Connect

After entering the login interface, enter the mobile phone number and password, and then click the login. After the login is successful, enter the APP connection page, as shown in Figure 29:



Figure29 Verification code login interface

Open the Bluetooth switch of the single -mode laser app. If there is a Bluetooth device nearby, ensure that the switch of the Bluetooth device is turned on and click the "Search" button on the connection page.



Figure30 connect

Click the "Connection" on the right side of the searched Bluetooth device to enter the connection state, as shown in Figure 31:



Figure31 connecting

4.13.3 Equipment

After the connection is successful, enter the laser device-status interface, as shown in Figure 32:



Figure32 device status

The device status page mainly includes the main power supply, equipment, alarm, and light state display, as well as the state of light percentage, light power, laser temperature status, and the state of emergency stop, REM, laser enablement, red light display, and laser device, and laser The specific state and some parameter values are displayed.

There is also a device-alarm page, as shown in Figure 33:

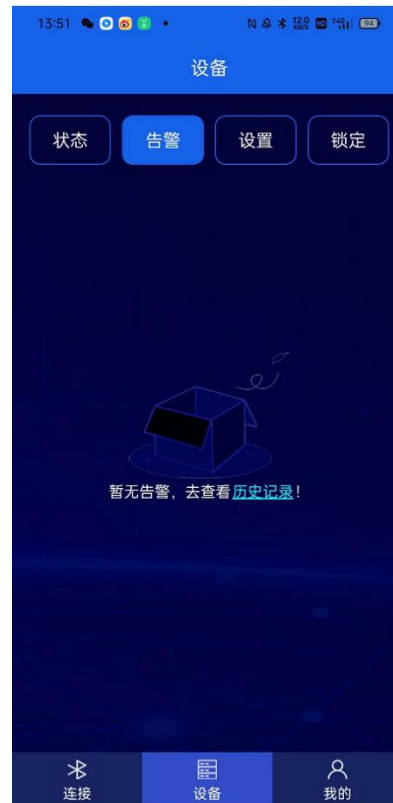

Figure33Equipment-alarm

If the device alarm page is connected to the laser, the laser is not alarm, and the interface will display "No alarm, check the historical records!", If there is a alarm state, the specific title of the alarm will be displayed.

The state display of the laser also has the setting function that supports some parameters. It can be visible in the device-settings interface, as shown in Figure 34:

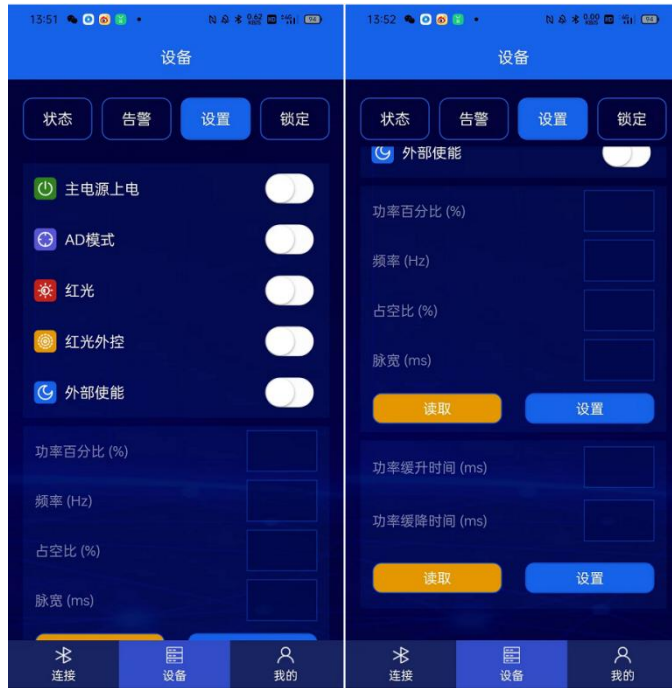

Figure34 Equipment-Settings

In the device-lock interface, the laser can be locked or unlocked to the laser through the device authorization code. The specific form of the page is shown in Figure 35:



Figure35 Equipment-Lock

4.13.4 My page

Entering my page, you can see function introduction, version update, and about machines, as shown in Figure 36.



Figure36 page

The function introduction interface is a specific introduction to the laser. As shown in Figure 37:

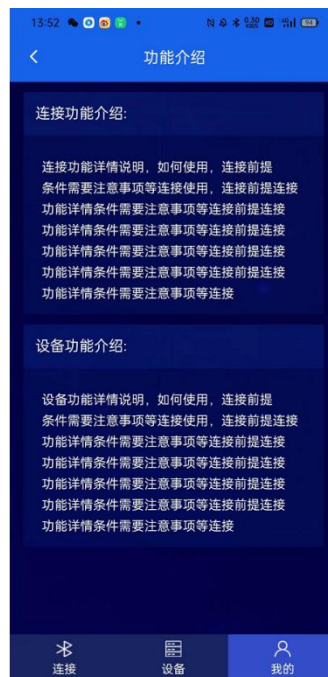

Figure37 Features

The version update interface is the content of the current version of the laser and the content of the upgraded version. As shown in Figure 38:



Figure38 new version update

Mine-about the machine page shows the relevant information of the laser, such as laser time, laser model, laser serial number, main control serial number, key version number, system information. As shown in Figure 39:



Figure39 Mine-About the machine

In my-about machine-system information page, and laser detailed information. As shown in Figure 40:



Figure 40 Mine-About Machine-System Information

4.13.5 Software introduction

The single -mode laser app is a mobile software that can be connected to the laser through Bluetooth to facilitate the after -sales, maintenance, and commissioning engineers, etc., without portable notebooks, you can use the single -mode laser app installed on Android phones to and the laser. Connect, read the state of the laser or set some parameters, which is conducive to the rapid, effective and convenient solution to some problems in the use of laser use.

5 Alarms and Solutions

5.1 Alarms Display

Connect the computer and open the host computer software, after the laser and the client software establish normal communication. All alarm states of the laser can be displayed on the host computer software interface, as shown in Figure 41. When the internal temperature of the laser is abnormal, the power is abnormal, the scattered light is abnormal, the power supply is abnormal, the condensation is abnormal, the flow rate is abnormal, etc., the laser will alarm.



Figure41 The homepage of the clientware

If any alarm occurs (except for Interlock alarm) when the laser is running, the clientware will display the alarm that occurs, and the ALARM light (yellow) on the front panel of the laser will light up, the laser will stop emitting and lock.

When the Interlock is abnormal, the output of Ready signal is low, and the Interlock state is abnormal in the clientware, but the laser is not locked, and the ALARM light (yellow) is not lit. The output of Ready signal is on high level when the Interlock is normal.

5.2 Alarm solutions

The instructions and solutions of alarms are as follows:

Table 12 Instructions and solutions for alarms of laser

Alarm name	Alarm instructions and solutions
T1/T2 Alarm	<p>Instruction: Low temperature/high temperature alarm of the laser. The sensor in the laser detects an abnormal temperature inside the laser. A high-temperature / low-temperature error occurs when the temperature at the monitoring point exceeds the set upper / lower limit.</p> <p>Solution: High temperature alarm, please check if the water-cooling system is normally working, the water temperature is set correctly, and the water connection is correct. When the water cooling system works normally and the water temperature drops below 30°C, restart the laser.</p>

	<p>Low temperature alarm, please check if the actual water temperature of the water is too low. In addition, a low ambient temperature may also cause a low temperature alarm when the laser is cold. Please wait until the water temperature of the water rises above 10°C.</p>
<p>Laser Water flow</p>	<p>Instruction: The water flow rate of the laser alarms. The current water flow rate detected inside the laser is lower than the required value, and there is a safety risk.</p> <p>Solution: Stop using the laser immediately. Please check the output model and working status of the laser water cooler and clean the laser water filter module according to the laser operation requirements in the section 3.3 cooling System Installation and Requirements. It is recommended to clean the water cooler and the water inlet filter assembly regularly, and replace the cooling water.</p>
<p>Scattered Light Alarm</p>	<p>Instruction: Scattering light alarm, when the intensity of ambient light inside the laser exceeds the set value, the scattering light alarm will be generated, and the laser emission function will be locked (cannot be unlocked). The scattered light alarm only occurs when the laser emission.</p> <p>Solution: Please restart the laser, check the guide laser state of the laser, and through the clientware "from the control module" reading the scattered light monitoring voltage value, and contact Raycus.</p>
<p>Laser Power Alarm</p>	<p>Instruction: The alarm is generated when the emission of the laser cannot reach the set value. Power error occurs only when the laser is emitting.</p> <p>Solution: Please restart the laser, check the red light state of the laser, and contact Raycus.</p>
<p>ACDC Alarm</p>	<p>Instruction: ACDC Error, failure of the laser power supply or sudden power failure of the power supply system may cause an alarm.</p> <p>Solution: Check if the input AC voltage is normal. Restart the laser, if this error continues to occur, please contact Raycus.</p>
<p>Current Driver Alarm</p>	<p>Instruction: Current Driver Alarm, this error occurs when the constant current driver board inside the laser is abnormal.</p> <p>Solution:</p>

Restart the laser, If this error continues to occur, please contact Raycus
--

In addition to the above, if there are any questions or errors in using of the laser, you can contact Raycus to get help.

6 Warranty, Return and Maintenance

6.1 General Warranty

Raycus warrants that all Raycus fiber laser products are conformed to applicable product specifications under normal use and are free from defects in materials and workmanship. The warranties start on the date of shipment from Raycus for a period of time as set forth in the applicable purchase contracts or product specifications. Raycus has the right to choose to repair or replace any product that proves to be defective in materials and workmanship selectively during the warranty period. Only products with particular defects are under warranty. Raycus reserves the right to issue a credit note for any defective products produced in normal conditions.

6.2 Limitations of Warranty

The warranty does not cover the maintenance or reimbursement of our product of which the problem results from tampering, disassembling, misuse, accident, modification, unsuitable physical or operating environment, improper maintenance, damages caused by those who are not from Raycus due to excessive use or not following the instructions. Customer has the responsibility to understand and follow this instruction to use the device. Any damage caused by fault operating is not warranted. Accessories and fiber connectors are excluded from this warranty.

According to the warranty, client should write to us within 31 days after the defect is discovered. This warranty does not involve any other party, including specified buyer, end-user or customer and any parts, equipment or other products produced by other companies.



◆ It is the customer's responsibility to understand and follow operating instructions in this UserGuide and specifications prior to operation-failure to do so may void this warranty. Accessories and fiber connectors are not covered by this warranty.

6.3 Service and Repair

- a) Do not open the device. There are no user serviceable parts, equipment or assemblies for user in this product. All service and maintenance shall be performed by qualified Raycus personnel.

- b) Please contact Raycus as soon as possible when problems under warranty about maintenance happened to the product.
- c) The product returned with permission should be placed in a suitable container.
- d) If any damage happened to the product, please notify the carrier in document immediately.

We reserve the right to make changes in design or constructions of any of our products at anytime without incurring any obligation to make changes or install the same on units previously purchased.

All the items about warranty and service above provided by Raycus are for user's reference; formal contents about warranty and service are subject to the contract.

© 2023 Wuhan Raycus Fiber Laser technologies Co. Ltd, All Rights Reserved.