



**Global Version RFL-C20000M-CE**  
**Continuous-Wave Fiber Laser**  
**User Guide**

# CONTENTS

1. Safety Information .....	1
1.1. Security Label .....	1
1.2. Laser Safety Grade .....	2
1.3. Optical Safety .....	3
1.4. Electrical Safety.....	3
1.5. Other Safety Rules .....	3
2. Product Description .....	4
2.1. Features .....	4
2.2. Package Parts .....	4
2.3. Unpacking and Inspection.....	4
2.4. Operation Environment .....	5
2.5. Attentions .....	5
2.6. Specifications .....	6
3. Installation .....	6
3.1. Dimensions.....	6
3.2. Installation rule .....	9
3.3. Protective end cap of output cable and using description .....	11
3.3.1 Types of protective end caps and factory status.....	11
3.3.2 Pre-installation cleaning instructions for output cables .....	12
3.4. Cooling Requirements.....	14
4. Using the Product .....	17
4.1. Front Panel.....	17
4.2. Rear Panel .....	18
4.3. Power connection .....	19
4.4. Control interface definition .....	20
4.4.1 Safety XP2 Interface .....	20
4.4.2 HARDWIRING XP1.....	21
4.4.3 RS232 XP3 Interface .....	24
4.4.4 Analog Interface XP4 .....	25
4.4.5 INTERNET Interface XP5 .....	25
4.5. Introduction to Safety Interlock.....	25
4.6. Schematic diagram of the internal electrical circuit of the laser .....	26
4.7. Start operation sequence.....	27
5. Control Mode Selection .....	28
5.1. ON Mode.....	30
5.2. AD Enable Mode .....	30

5.3. Emission External Control Enable .....	30
5.4. Guide Laser (Red Guide Beam) Control .....	31
5.5. Programming Mode .....	31
5.6. REM Mode .....	31
5.6.1 AD enable mode .....	31
5.6.2 Emission external control.....	32
5.6.3 Red light control .....	32
5.6.4 Programming Mode .....	32
6. Laser Wiring Diagram and Operation Steps .....	33
6.1. Internal control in ON Mode.....	33
6.2. Laser Operating in External Control Mode .....	34
6.3. In ON Mode, the Laser Emission Power is Externally Controlled by Analog Signal .....	35
6.4. Laser Operating in External Control Programming Mode.....	36
6.5. Set the Power Analog Quantity in REM Mode to Control the Laser Emission .....	37
6.6. Power Communication Setting in REM .....	38
6.7. Programming Mode in REM Mode .....	39
7. RS232 and INTERNET communication command .....	40
7.1. Port Configuration.....	40
7.2. Laser Communication Protocol (Network Port & Serial Port).....	41
8. PC software instructions .....	45
8.1 Maininterface of PC software .....	45
8.2 Multi-laser control area .....	46
8.2.1 Add/delete laser .....	47
8.2.2 ModifylaserIP .....	48
8.3 Main working status display .....	48
8.3.1 Laser’s cumulative operating time display area .....	49
8.3.2 Laserworkingstatusdisplayarea .....	49
8.3.3 Laser power-up, mode selection, light-out control area.....	51
8.3.4 Programming mode test area .....	51
8.3.5 Power slow rise&down parametersettingarea .....	52
8.3.6 Laser output parameters read the settings area.....	52
8.4 Laserparameterdisplayarea .....	53
8.5 Alarm type display area .....	53
8.6 PC softwareoperatingmodeselection.....	53
8.7 LanguageDisplays laser’s all status and parameters for diagnosis purposes .....	55
8.8 Authorization (time-limited locking) .....	55
8.8.1 Authorization in user mode.....	55
8.8.2 Authorization in authorization mode .....	56

8.9	About .....	57
8.10	XP1 interface status indication (in diagnostic mode).....	58
8.11	Log (in diagnostic mode) .....	59
8.11.1	Download log .....	60
8.11.2	Downloadrecord of historicalfault .....	60
8.11.3	Downloaded file address .....	61
8.12	Module parameters (in diagnostic mode) .....	61
8.13	Programming settings (programming editing).....	61
8.13.1	View the number of wave bars inside the current laser .....	62
8.13.2	Check waveform content .....	63
8.13.3	Empty all waveforms .....	63
8.13.4	Editwaveform .....	64
8.13.5	Command explanation .....	66
9.	Warranty, Repair and Return .....	68
9.1.	General Warranty .....	68
9.2.	Limitations of Warranty .....	68
9.3.	Service and Repair.....	68
9.4.	Scrap requirements.....	69

## 1. Safety Information

Thankyou for choosing Raycus Fiber Laser. This user manual provides you with important safety, operation, maintenance and other relevant information. Please read the manual carefully before using this product. To ensure safe operation and optimum product operation, please observe the following cautions and warnings as well as other information within this manual.

### 1.1. Security Label

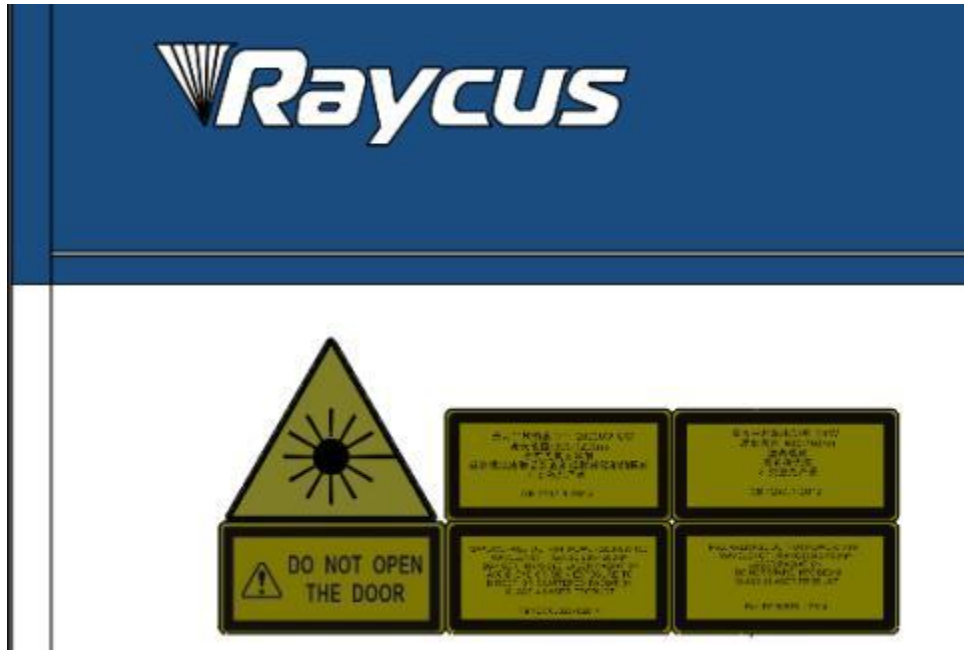











Figure 1security lable

	<p><b>WARNING:</b>Describes a hazard that leads to severe injury or death to people.</p>
	<p><b>CAUTION:</b> Describes a hazard that leads to general injury to people or damages to product.</p>

 <p>English</p> <p>Chinese</p>	 <p>English (20000W)</p> <p>Chinese (20000W)</p>	 <p>English</p> <p>Chinese</p>
<p>1:Laser Emit Head</p>	<p>2: Type 4 Laser Product</p>	<p>3: Class 2 Laser Product Label- 1mW Red Laser</p>
		
<p>4: CE Authentication</p>	<p>5: ID Label (20000W)</p>	<p>6: Laser Radiation Hazard</p>
		
<p>7:Electrical Hazard</p>		

### 1.2. Laser Safety Grade

According to European Standard EN 60825-1, Clause 9 and Chinese Standard GB 7247.1-2012 Safety of Laser Products Part 1: Equipment Classification Requirements, this series of lasers are Class 4 laser instruments. The product emits laser radiation at a wavelength of 1080 nm or around 1080 nm, and the average laser power radiated from the output head is 20 kW. Direct or Indirect exposure to high power laser radiation causes damage to the eye or skin. Although the radiant laser is not visible, the beam will cause irreparable damage to the retina or cornea, so appropriate and certified laser safety glasses must be worn throughout the laser emitting.

	<p><b>WARNING:</b>Users must use appropriate laser goggles when operating this device. The laser goggles should be selected according to the range of wavelength emitted from this product. Users must ensure that the protect range of laser goggles over the entire range of laser wavelengths. Please do not directly view the laser output head when laser emitting.</p>
---	--

### 1.3. Optical Safety

Any dust on the end of the collimator assembly can damage the crystal of output head or the entire laser device.

	<p><b>CAUTION:</b> DO NOT emit when the protective cap is not removed, otherwise the lens or crystal will be damaged.</p>
---	---

### 1.4. Electrical Safety

a) Ensure that the PE line is effectively grounded, and the installation environment is safe and reliable.

	<p><b>WARNING:</b> The disconnection of the product grounding will electrify the enclosure, which may result in personal injury to the operator.</p>
--	--

b) Ensure that the AC voltage is supplied normally.

	<p><b>CAUTION:</b> Wrong wiring mode or power supply voltage will cause an unrecoverable damage to the laser device.</p>
---	--

### 1.5. Other Safety Rules

a) Do not view the laser output head directly when laser is emitting.

b) Do not use fiber lasers in dark or dim environments.

c) If this device is used in a manner not specified in this document, the protection provided by the device may be impaired and the warranty will be voided.

d) There are no user serviceable parts, equipment or assemblies inside the product. All service and maintenance shall be performed conducted by a certified Raycus engineer. In order to prevent electric shock, please do not break the seal or uncover the shield. Failure to comply with this instruction will be treated as invalid warranty.

## **2. Product Description**

### **2.1. Features**

Fiber lasers are more compact and ready to use than conventional laser structures, with higher electrical and optical conversion efficiencies, lower power consumption and better beam quality. Thanks to its flexible laser output, it can be easily integrated with system equipment.

Main Features:

- ⊕ High beam quality
- ⊕ High reliable
- ⊕ Free-maintenance operation
- ⊕ High electro-optical conversion efficiency
- ⊕ Convenient control interface
- ⊕ Fast modulation

Applications:

- ⊕ Industrial cutting and welding
- ⊕ Scientific research

### **2.2. Package Parts**

Please refer to package accessories are in the packing box.

### **2.3. Unpacking and Inspection**

Through the specially designed packaging materials and cabinets, Raycus ensures that the lasers are fully protected during transportation. Nevertheless, in order to prevent unpredictable situations during transportation, the users still need to carefully check whether the package is correctly placed before unpacking, and there is no damage from phenomenon such as collision, cracking and flooding on the outside of the box. Once you find that there is an abnormality in the external cabinet, please inform Raycus Company in time to deal with it as soon as possible.

Please double check if each listed content is inside the package; and contact Raycus as soon as possible if there are any issues.

Take extra care when removing the unit from the package and make sure that the fiber optic cable stays away from any possible collision and vibration. Please do NOT distort, bend or pull the output cable when unpacking the device; and avoid any collision to the head of laser output.





**CAUTION:** The fiber optic cable and output head are precise optical instruments, ANY vibration or impact to the output head, and twist or excessive bend to the cable will damage the instrument.

## 2.4. Operation Environment

The operation conditions are listed as the following table:

Table 1 The Operation Environment Conditions for the Laser

Model	RFL-C20000M-CE
Supply voltage (V)	Three-phase four-wire system AC 323V~AC 437V、50/60Hz (including PE)
Power supply capacity (kVA)	>65
Water cooling flow (L/min)	>167
Installation Environment	Flat, no vibration nor impact
Ambient Temperature	10℃~40℃
Relative Humidity	<70%

- a) Make sure the product is properly grounded before use.
- b) The laser output head is connected with fiber optic cable. Please inspect the output head carefully for dust or other contaminations. Use appropriate lens paper to clean it if necessary.
- c) Failure to follow the instructions when operating the laser may cause malfunction and damage.
- d) It is not allowed to install the output head when the laser is in operation.
- e) Do not look into the output head directly. Wear appropriate protective eye glasses all the time when operating the laser.

Tips: Install the laser in an air-conditioned environment for longer life and better performance.

## 2.5. Attentions

- a) Make sure that the correct voltage of 380VAC is used. Connecting failure of power supply will damage the device.
- b) The output laser is collimated by the collimating lens, it is important to keep the collimating lens clean, otherwise it will damage the device.
- c) Please cap the output head when it is not in use. Do not touch the output lens at anytime. Use appropriate lens paper to clean it if necessary.
- d) Safety keep the cap when using the laser. To avoid dust, make sure the opening direction of the cap is put down.
- e) Failure to follow the instructions may cause laser power loss, such loss is not covered by warranty.

## 2.6. Specifications

Table 2 Product Specifications

Optical properties		Test Conditions
Model	RFL-C20000M-CE	
Output Power(kW)	20	/
Operation Mode	CW/Modulated	/
Polarization State	Random	/
Output Power Tunability (%)	10~100	/
Emission Wavelength(nm)	1080±5	Nominal Output Power
Output Power Unstability	±1.5%	Nominal Output Power; Duration: 5hrs; Ambient Temp.: 25℃
Modulation Frequency (Hz)	50~5k	Nominal Output Power
Red Guide Laser Power(mW)	0.5~1	/
Fiber output Types	QP	/
Beam Quality (BPP, mm•mrad)	3.5~4.3@1/e <sup>2</sup>	Nominal Output Power
Fiber core diameter (μm)	100	customizable
Delivery Cable Length(m)	30	customizable
Electrical characteristics		
Operating Voltage	Three-phase four-wire system AC340V~AC420V、50/60Hz (Include PE)	/
Maximum power Consumption (kW)	57	/
Control Method	Serial communication / AD	/
Other characteristics		/
Dimension WxHxD (mm)	960x1530x1160 (mm)	Includes casters and rings, without warning lights
Weight (kg)	<700	Air conditioning included
Operating Ambient Temperature (°C)	10~40	/
Humidity (%)	<90	/
Storage Temperature (°C)	-10~60	/
Cooling Method	Water cooling	/

## 3. Installation

### 3.1. Dimensions

The main body dimensions of RFL-C20000M-CE continuous fiber laser are shown in Figure 2.

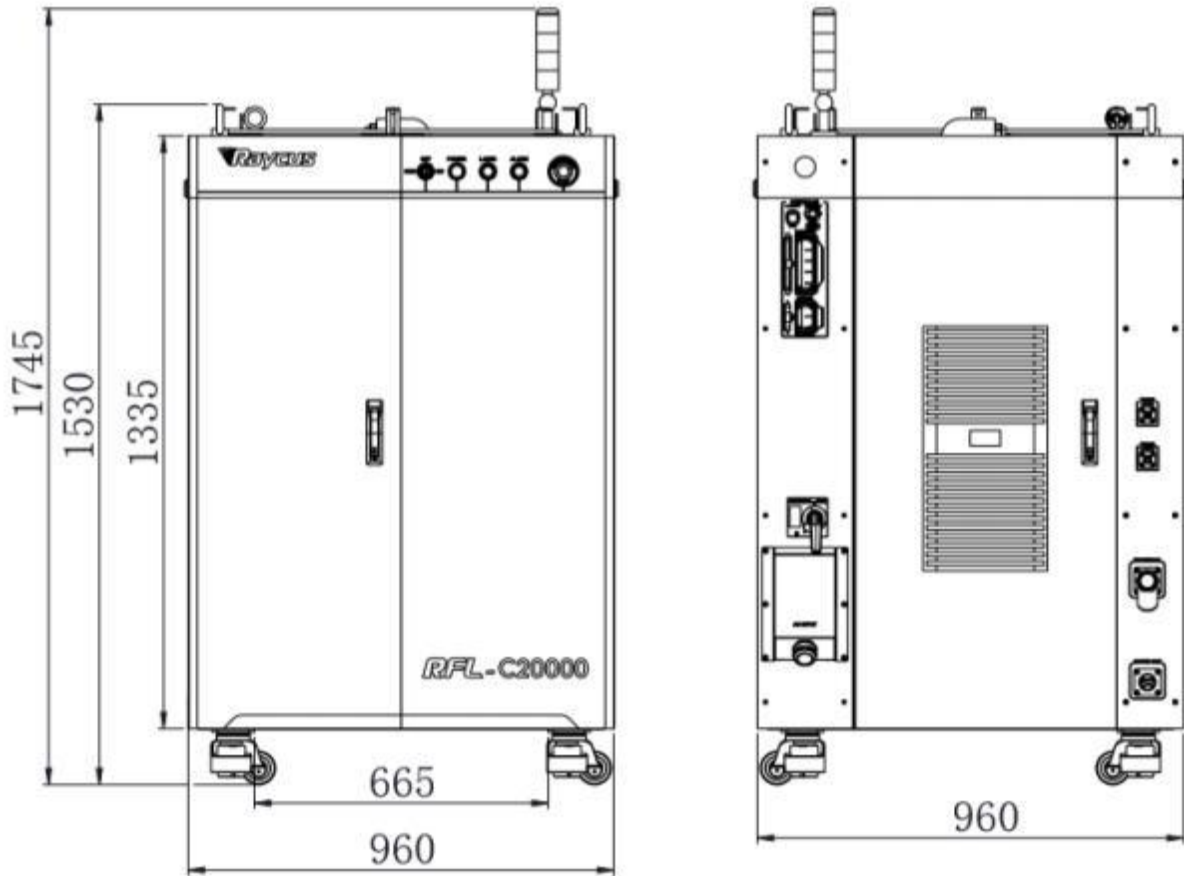

Figure 2-a Front and rear view of the laser.

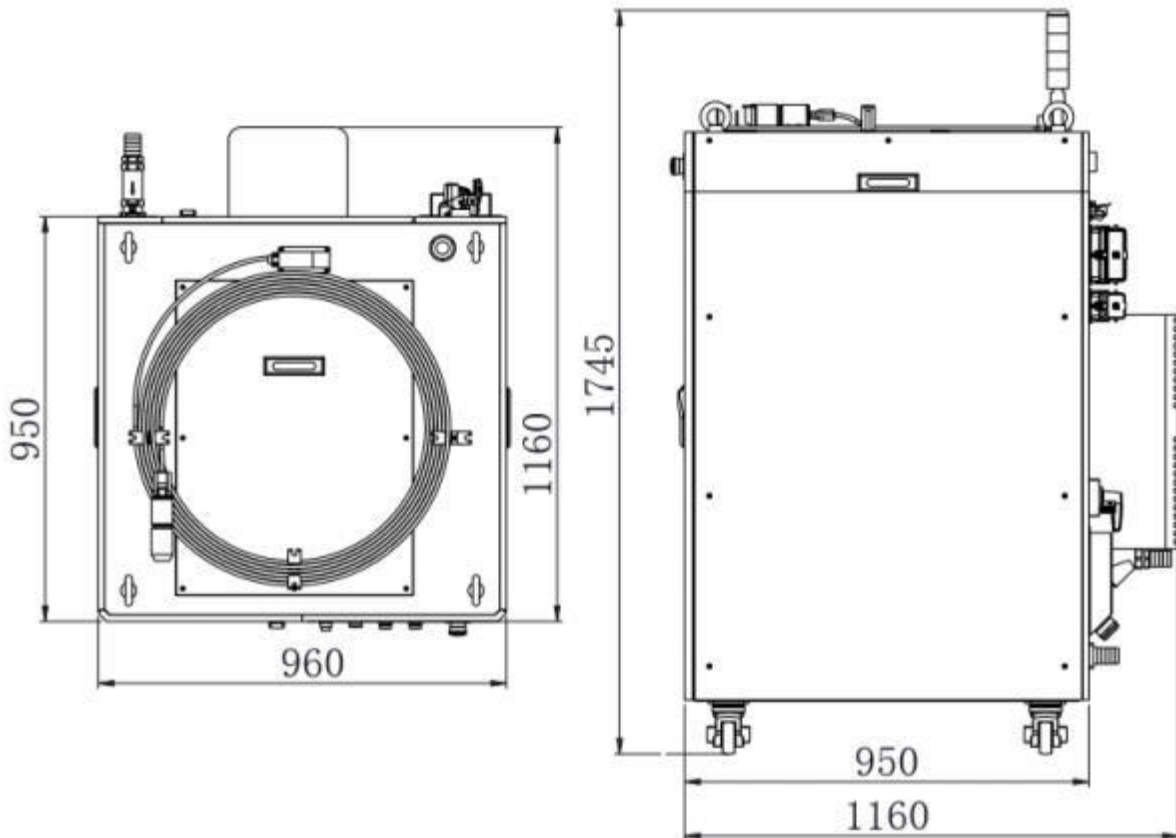

Figure 2-b Top and left view of the laser.

Figure 2 The dimensions of RFL-C20000M-CE continuous fiber laser

The structure size of RFL-C20000M-CE laser is 960x1530x1160mm (width×height×depth; including casters and rings, without warning light); RFL-C20000M-CE laser weighs less than 700kg.

The RFL-C20000M-CE continuous fiber laser uses the RFL-QP output optical cable, and the external dimensions of the output optical cable head are shown in Figure 3.

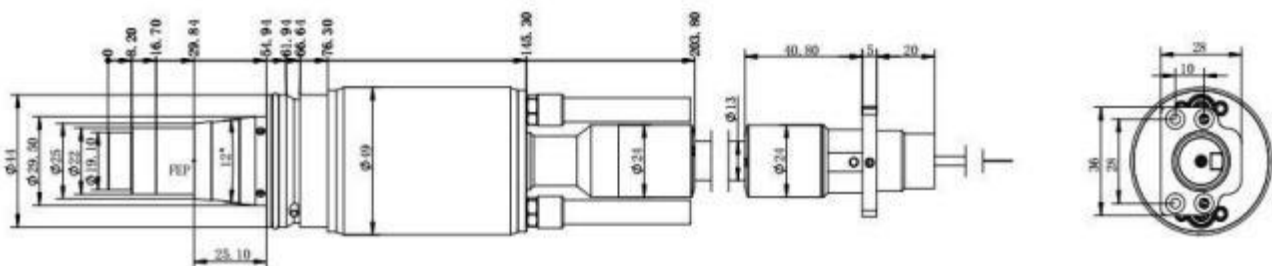

Figure 3 External dimensions of the RFL-QP output optical cable head

**Note: The dimensions in the above diagram are in the unit of mm.**

Before the laser works, make sure that the two copper contacts (Interlock pins) on the output head are shorted, otherwise the laser will not work properly. Before installing the output cable into the processing head, the lens of the output cable must be inspected. If the output cable lens is dirty, the lens

must be cleaned. It is forbidden to disassemble the output lens by anyone other than staff in Raycus, otherwise the warranty will be invalidated.

### **3.2. Installation rule**

- a) Place the laser horizontally in a suitable position and fix it as necessary;
- b) Before the laser is powered on, Please check if the power supply has the correct voltage (380VAC $\pm$ 10%, 50/60Hz, See Table 2 Product Technical Data Sheet for details.), whether the grounding line is well grounded;
- c) Connect the power cable and control cable to the product when power supply is OFF;
- d) Connect the cooling system to the laser and output optical cable head according to the water inlet and outlet signs;
- e) Please check the laser output head and make sure to clean it before installing it in the equipment;
- f) Do not step on, squeeze or excessively bend the protective tube during the installation of the output optical cable to avoid damage to the optical fiber;
- g) In the process of installing the optical cable output head, ensure the cleanliness of the surrounding environment (do not use electric fans to dissipate heat when it is hot in summer to avoid large dust in the air);
- h) The minimum bending diameter of the laser transmission cable in non-working conditions such as transportation and storage shall not be less than 40cm. When the laser is emitting light, the minimum bending diameter shall not be less than 60cm;
- i) Customers can use the four lifting rings at the top of the product or the four casters at the bottom to lift or move the product. Before lifting the laser source, make sure that the four lifting rings are installed firmly and reliably. When lifting the laser source, be sure to use the four lifting rings; when pushing the laser source, please make sure that the support block at the bottom of the horizontal adjustment caster is off the ground. After the laser source is positioned, adjust the support block to make it contact the ground to avoid displacement of the laser source. As shown in Figure 4.

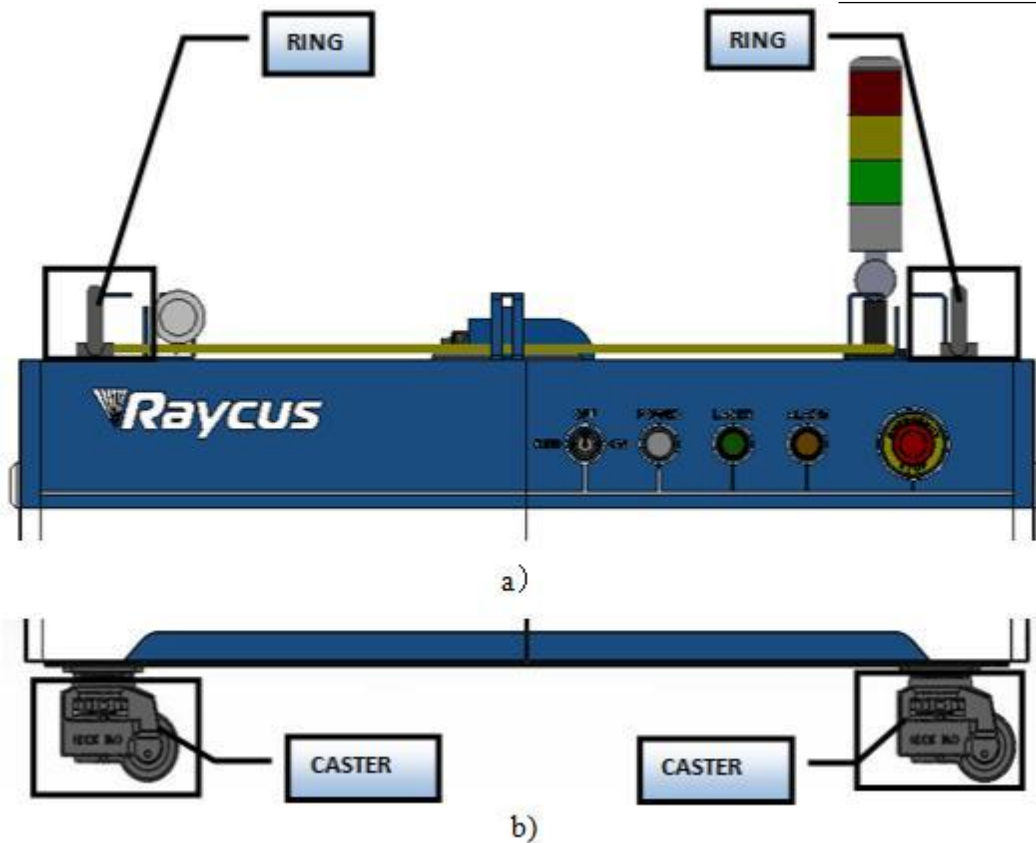





Figure 4 Laser top lifting ring and bottom level adjustment caster.

	<p><b>CAUTION:</b> All the cables can only be connected when power supply is off. Hot plug may damage the device.</p>
	<p><b>CAUTION:</b></p> <ul style="list-style-type: none"><li>(1) The placement of the laser output cable should be as natural as possible, and the output cable should not be twisted;</li><li>(2) If the coil diameter of the output optical cable is too small, it will damage the laser.</li></ul>
	<p><b>CAUTION:</b></p> <ul style="list-style-type: none"><li>(1) In the process of installation and disassembly, please handle the laser output head gently, and avoid vibration;</li><li>(2) Before assembling the laser output head, ensure that the optical lens and cutting head cavity are clean and free of pollution.</li></ul>

### 3.3. Protective end cap of output cable and using description

#### 3.3.1 Types of protective end caps and factory status

For multi-module high-power fiber lasers, the output cable type used is QBH/QD/QP output optical cable. There are two types of protective end caps in the machine, as shown in the figure. Type A end cap: It is assembled on the output optical cable when it leaves the factory. The end cap is equipped with a protective window to ensure the cleanliness of the end cap (or crystal) during transportation.

Type B end cap: It is attached to the packaging accessories and is generally packed in a lamination box. The end cap is not equipped with a protective window, which is used to prevent the end cap from being damaged when the optical cable is loaded with the cutting head (or welding head).

Table 3 Instructions for the use of protective end caps for output optical cables

Model	Optical cable model	Factory end cap type	Use end cap type
RFL-C20000M-CE	QP	Type A end cap (with protective windows )	Type B end cap (without protective window )

**Note:** According to the difference of the protective end cap of the cable in the actual use of the customer, some models need to replace the protective end cap. Please refer to the " Cleaning Instructions for the Output Optical Cable Before Installation " to clean the output optical cable and the protective end cap.

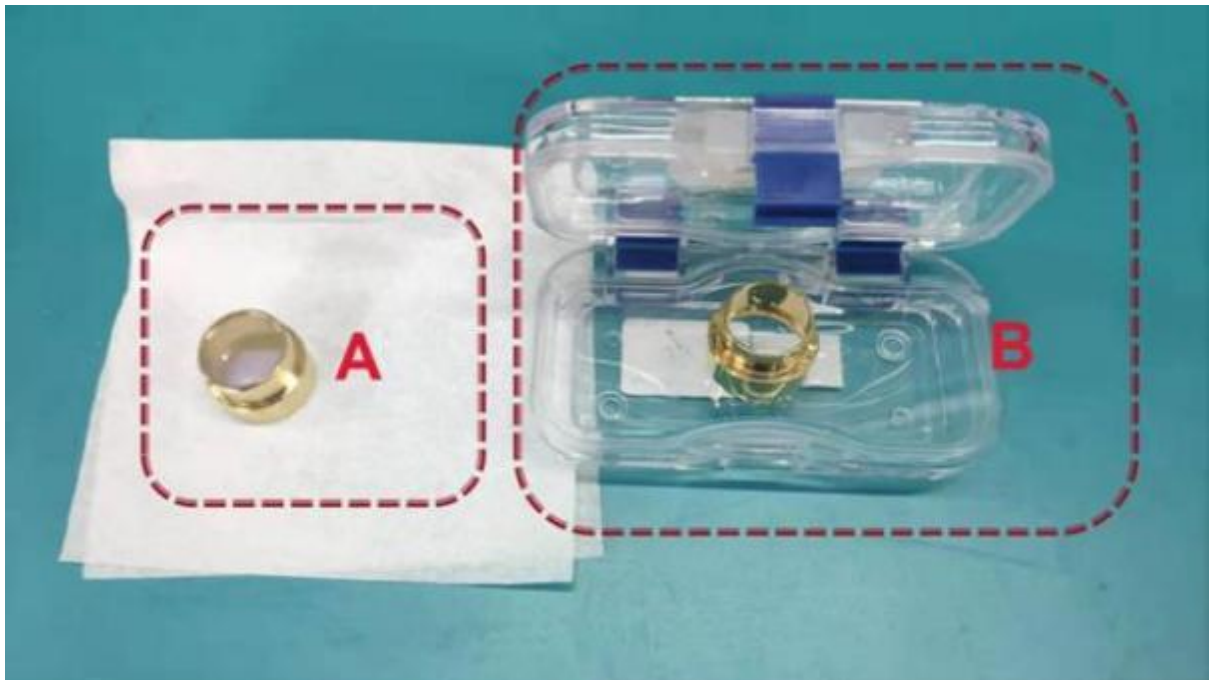

Figure 5 Schematic diagram of the protective end cap of the optical cable

### 3.3.2 Pre-installation cleaning instructions for output cables

a) Preparation tools

Cleaning agent: absolute ethanol, or isopropyl alcohol.

Cleaning tools: cleaning cotton swabs, dust-free paper, compressed air bottles, etc.

b) Steps

clean workbench should be turned on for at least 5 minutes , and the output optical cable should be taken out of the black packaging box



Figure 6 Output cable placed in the box

c) Place the output optical cable in a clean workbench;

Note: The following operations need to be carried out in a clean workbench. If the operation is not carried out in a clean environment, it will cause great risk to the QP output optical cable; operators need to wear finger cots to operate.



Figure 7 The output optical cable placed in the clean bench with the ventilation turned on

d) Remove the white dust cap and place it face down on new lint-free paper.

Note: The dust-free paper is for one-time use, and there is a risk of dust falling if it is used multiple times.





Figure 8 Output optical cable with white dust cover removed

e) Use a cotton swab and anhydrous ethanol to clean the metal casing of the optical cable, then remove the end cap (with window) attached to the optical cable, and place it on a clean paper .



Figure 9 Remove the A -type end cap on the optical cable

f) Check the cleanliness of the end caps in this state. If the cleanliness is not enough, please clean the end caps. Please refer to the cleaning method:

<http://www.raycuslaser.com/view/1852.html> , video reference:<https://mp.weixin.qq.com/s/hRXrPkb8DAyvDYegSWwYLg> .

**Note: The end cap cleaning is generally performed by our professional staff. If the customer needs to operate it by himself, we need to go through the relevant training of our staff and obtain the relevant qualifications before the above operations can be carried out. If the operation method is improper, it will cause irreversible and serious damage to the output optical cable during use.**

After ensuring the cleanliness , install the B- type end cap. During the installation process, there will be resistance when screwed to the bottom, which is a normal phenomenon. It is necessary to ensure that there is no gap between the end cap and the main body sleeve. And then check the finish and cleanliness of the end cap's glossy surface, as Figure shown. Then connect the fiber

optic cable output head to the cutting head (or welding head) with the B- type end cap installed. This operation needs to ensure the cleanliness of the inner and outer surfaces of the cutting head (or welding head) connector.

**Note: The connection with the cutting head (or welding head) still needs to be carried out in a clean workbench, and it is necessary to check the cleanliness and smoothness of the relevant components of the cutting head (or welding head) itself.**

Keep the corresponding accessories as shown in order to facilitate there-transportation of the laser or output cable.

**Note: The fiber optic cable must be loaded with Type A end caps each time it is transported. That is, every time the output optical cable is unloaded from the cutting head and needs to be transported, the end cap of type B must be replaced with the end cap of type A , and the white dust cover must be covered, and finally put into a black box for transport.**



Figure 10 Accessories that customers need to keep: black protective box, white dust cover, type A end cover

### 3.4. Cooling Requirements

Table 4 Cooling Requirements

Model	Cooling capacity (kW)	Minimum flow (L/min)	Input pressure (Bar)	Hose inner diameter (mm)	Cooling water temperature (°C)
RFL-C20000-CE	≥40	>167	4~6	Φ38	22±1

Requirements on Cooling Water:

- a) The laser source cooling water connection is shown in Figure 10, and the arrow direction indicates the water flow direction;
- b) Cooling water needs to use pure water;
- c) In order to prevent the water in the water cooler from growing mold and causing pipeline blockage, it is recommended to add alcohol when filling pure water, and the amount of alcohol added is 10% of pure water;
- d) If ambient temperature is between  $-10^{\circ}\text{C}$  and  $0^{\circ}\text{C}$ , must be used to use 30% alcohol (volume ratio), and replace it every 2 months;
- e) If ambient temperature is below  $-10^{\circ}\text{C}$ , the chiller with both heating and cooling functions must be used, and keep it in full-time operation;
- f) For the connection of cooling water and normal temperature water circuits, please use Raycus supporting water pipes. If the water pipes are self-distributed, please do not increase the length of the water pipes and change the inner diameter of the water pipes;
- g) The tightening torque of the clamps for the cooling water circuit water pipe should be greater than  $6.5\text{N} \cdot \text{m}$ , and the tightening torque of the clamps for the normal temperature water circuit should be greater than  $5\text{N} \cdot \text{m}$ .

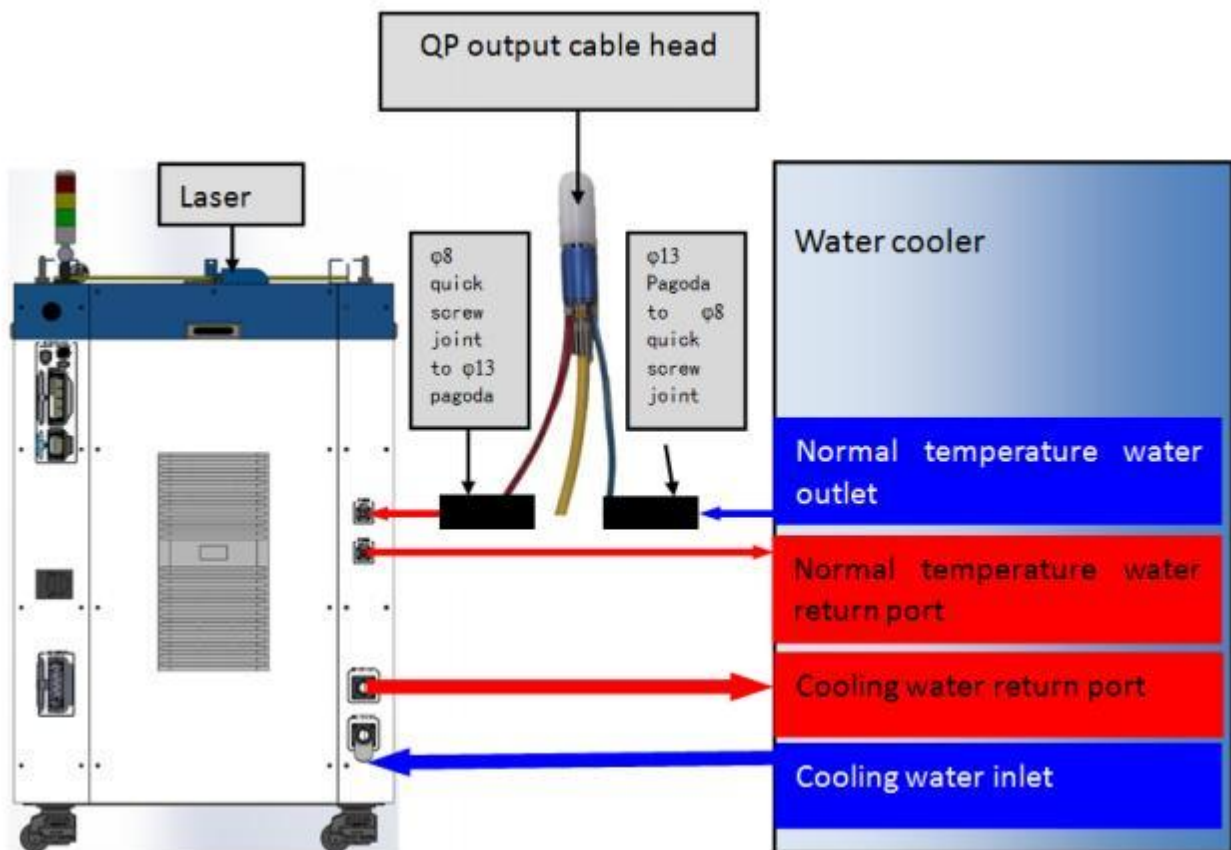

Figure 11 diagram of laser cooling system connection

Water cooling requirements for output optical cables:

- a) Water flow requirements: QP output cable water flow is greater than 3.0L/min;
- b) Water cooling pressure: 0.4~0.6Mpa at the water inlet;
- c) Water inlet and outlet connector type: M6 to  $\phi 8$  quick-tightening connector;
- d) Water pipe type: outer diameter  $\phi 8$  and inner diameter  $\phi 5.5$ ;
- e) Cooling water quality: deionized water, distilled water, purified water; it is recommended to replace once a month, and the replacement period should not exceed two months.
- f) PH value of cooling water: 5.0~8.0;
- g) The water cooler needs to be equipped with a filter element whose filter particle size is less than 100um; the filter element needs to be cleaned once a month.
- h) Maximum cooling water temperature: 35°C;
- i) The lowest cooling water temperature: 5°C greater than the saturated dew point temperature;
- j) Additives in cooling water: meet the above PH value and solid particle size requirements;
- k) Armored pipe bending radius: in non-working conditions such as transportation and storage, the minimum bending diameter shall not be less than 30cm. When the laser is emitting, the minimum bending diameter shall not be less than 40cm;
- l) Long-term vibration, less than 2G; impact, less than 10G.

**Other requirements:**

- a) When starting the cooling system for the first time, check the entire water system and joint for water leakage.
- b) If the laser is not used for a long time, the cooling water inside the cooling system and the laser inside should be drained, otherwise the laser equipment will be damaged.
- c) Please use compressed gas below 0.5MPa when emptying water from the device. Failure to do so may cause permanent equipment damage to cooling system.



**CAUTION:**

- (1) Set the water temperature of the cooling system correctly according to the ambient temperature. Setting the water temperature too high will result in the laser not working properly. Setting the water temperature too low will cause condensation inside the laser or the laser output head, which will cause damage to the laser;
- (2) Before turning on the laser, the cooling system must be working properly and the water temperature should be suitable for the temperature.

## 4. Using the Product

---

△ Please login to the official website of Raycus to download the new PC software and the PC software user manual. Website: <http://www.raycuslaser.com>

---

### 4.1. Front Panel

Figure 12 shows the front panel.

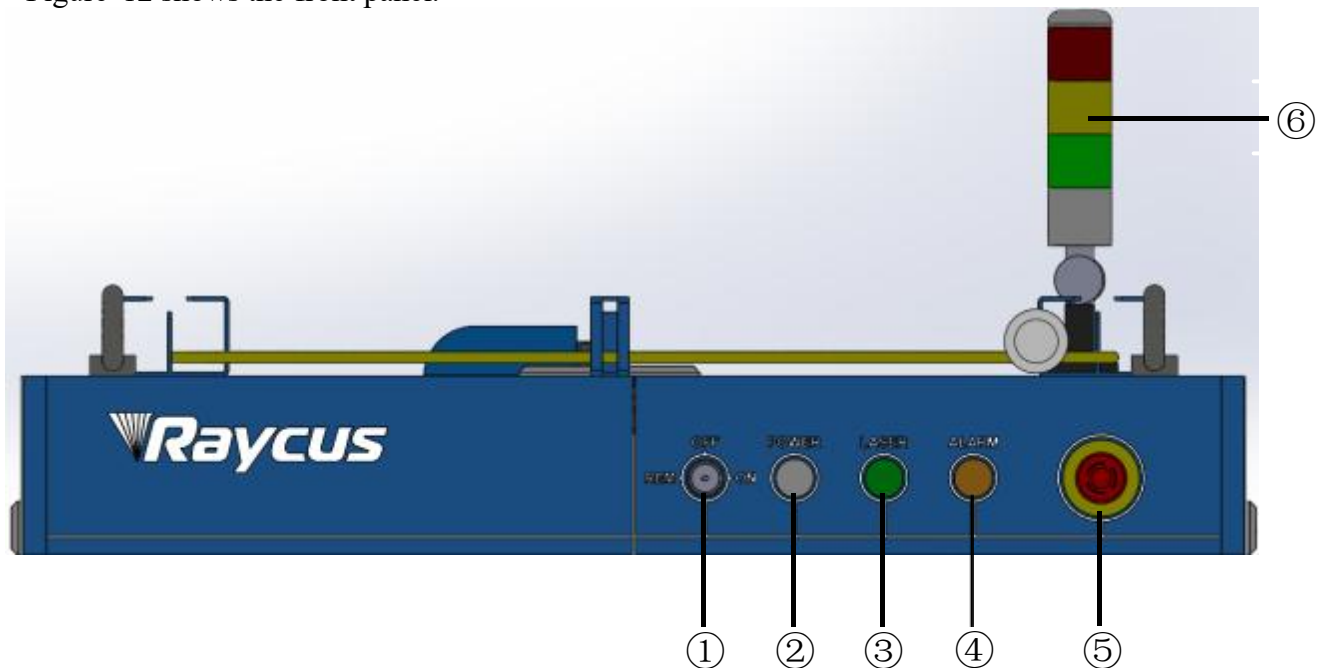

Figure 12 Front view of the panel

Note: ①-REM/OFF/ON ②-POWER ③-LASER  
④-ALARM ⑤-STOP ⑥-INDICATOR LIGHT

**REM/OFF/ON:** The key switch, the main control switch of the laser. Insert the key and turn it to the "ON" position, the main control part of the laser is powered on, and the POWER light is on; Rotate to the "REM" position, you need to close the 8 and 9 pins of the XP2 interface on the rear panel to realize remote power-on, and rotate to REM to activate the hard-wired control mode of the laser.

**POWER:** Control power indicator, when the white indicator light is on, it means the main control system is on.

**LASER:** The power button of the laser main power supply has a green light indicator function. After the laser main control system is powered on and all INTERLOCKS are detected as normal, press this button, the laser main power supply is powered on, and the button lights up after the main power supply is powered on.

**ALARM:** INTERLOCK alarm indication, the ALARM indicator lights up during the power-on self-check on the control panel. After the self-inspection is completed, all INTERLOCK interfaces are normally closed, and the ALARM indicator is off. During the operation of the laser, if any INTERLOCK is disconnected and the laser preparation is not completed, the indicator light will be on.

**STOP:** Emergency stop button, press to turn off the main power of the laser immediately; turn the button clockwise to release the button, and press the LASER button again to start the main power of the laser.

**INDICATOR LIGHT:** After the main power supply of the laser is powered on, the green indicator light is on when the laser is Ready; when the laser is emitting light, the red indicator light is on; when the laser has a fault, the yellow indicator light is on, accompanied by an alarm sound.

#### 4.2. Rear Panel

Figure 13 shows the rear panel.

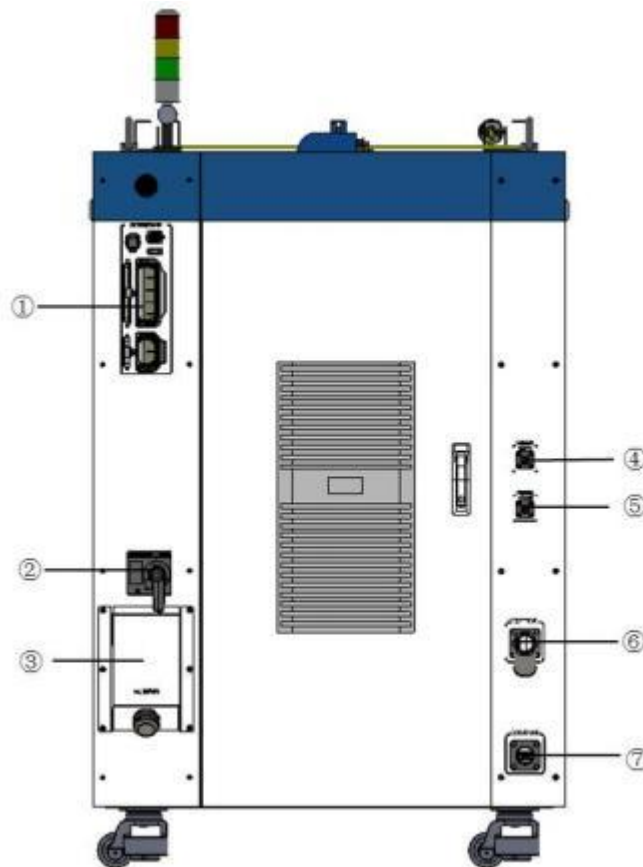

Figure 13 Rear view of product panel.

- Note: ①-INTERFACE      ②-BREAKER      ③-AC INPUT  
④-FIBER WATER IN   ⑤-FIBER WATER OUT   ⑥- WATER OUT  
⑦- WATER IN      ⑧-Filter

①-**INTERFACE**:This interface provides all control signals, including: RS232 communication, laser on/off control, laser remote control mode selection, analog control, modulation signal, Interlock interface, etc.Refer to Table 4 for the definition of control lines. This socket comes with a protective cover and a lock. When you are not using the product, you can cover the power input socket with the protective cover and lock it with the lock.

②-**BREAKER**:The circuit breaker (air switch) on the rear panel of the laser is the main power switch of the laser.

③-**AC INPUT**:The power input socket must be matched with the cable provided by us.

④-**FIBER WATER IN**:Output optical cable water inlet interface, this interface is connected to the water outlet of the normal temperature water of the water cooler, and connected to the  $\phi 13$  inner diameter water pipe.

⑤-**FIBER WATER OUT**:Output optical cable water outlet, this interface is connected to the output optical cable water inlet, connected to the  $\phi 13$  inner diameter water pipe.

⑥- **WATER OUT**: The water outlet of the laser, this interface is connected to the cooling water return port of the water chiller, and connected to the  $\phi 38$  inner diameter water pipe.

⑦- **WATER IN**: Thewater inlet of the laser, this interface is connected to the water outlet of the cooling water of the water chiller, and connected to the  $\phi 38$  inner diameter water pipe.

### 4.3. Power connection

	<p><b>CAUTION:</b></p> <p>(1) Before connecting to the AC power supply, please check whether the supplied AC power supply meets the requirements in Table 1;</p> <p>(2) Incorrect wiring will cause damage to the laser, so please check whether the power cord is connected correctly before powering on the laser.</p>
---	--

The definition and parameter requirements of the AC input line interface are shown in Table 5.

Table 5The interface definition and parameter requirements of AC input line.

RFL-C20000M-CE power cable			
NO.	LABLE	specification	color
AC380V-L1	L1	25mm <sup>2</sup>	BROWN
AC380V-L2	L2	25mm <sup>2</sup>	BLACK
AC380V-L3	L3	25mm <sup>2</sup>	GREY
PE	PE	16mm <sup>2</sup>	YELLOW/GREEN

The standard length of RFL- C20000M-CE provided by Raycus is 15 meters.

#### 4.4. Control interface definition

This type of laser does not provide a control signal line, only a control signal connector. The appearance of the joint is shown in Figure 14.

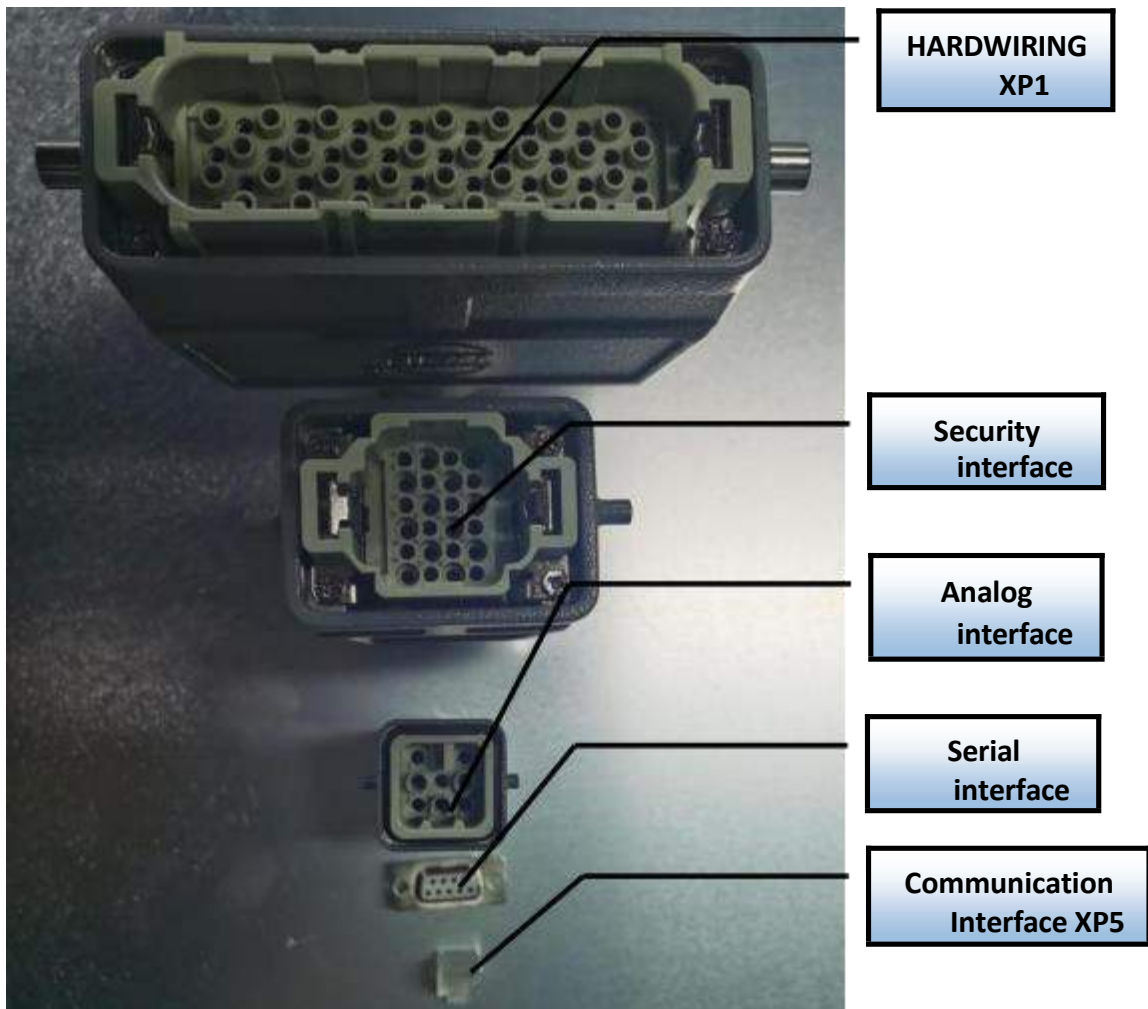

Figure 14 Control signal line

##### 4.4.1 Safety XP2 Interface

24-pin safety interface, with remote control system power-on, remote main power power-on and active and passive output of some lasers. The detailed interface definition is shown in Table 6.

Table 6 XP2 security interface definition

Pin number	type	description
1	MOD+	Output control, differential voltage input signal; laser ON: 4~30V;laser OFF: -3~2V; Maximum modulation frequency: 5kHz.
2	MOD-	



3	OUT (FET S pole)	Laser output indication, MOS pipe D, S output; current < 0.1A, $V_{DS}$ < 30V, passive signal.
4	OUT (FET D pole)	
5	OUT	Connect the negative pole of the external laser-emitting indicator, current <
6	OUT	Connect the negative pole of the external power-on indicator, current <
7	OUT (24V)	Connect the positive pole of the external laser-emitting indicator; active signal, current < 400mA
8	IN	On REM mode, the main control board is powered on when pin-8 and pin-9 are closed; 24V active contact Output, no external voltage or grounding.
9	IN	
10	24V OUT	Connect the positive pole of the external power-on indicator; active signal, current < 400mA
11	OUT	Emergency output 1 on the front panel, relay output contact, passive contact, current < 100mA, voltage < 30V; If the current panel stop pressed, pin-11 and pin-14 are open, or else close.
14	OUT	
12	OUT	Emergency output 2 on the front panel, relay output contact, passive contact, current < 100mA, voltage < 30V; If the current panel stop pressed, pin-12 and pin-13 are open, or else close.
13	OUT	
15	OUT (FET S pole)	Main power supply power on output indication, MOS pipe D, S output current < 0.1A, $V_{DS}$ < 30V, passive signal.
16	OUT (FET D pole)	
17	IN	Interlock1 input, the pin-17 and pin-20 should be closed normally; active contacts, no external voltage or grounding.
20	IN	
18	IN	Interlock2 input, the pin-18 and pin-19 should be closed normally; active contacts, no external voltage or grounding.
19	IN	
21	IN	Close the pin-21 and pin-22 to start the main power supply remotely. (The function is the same as the LASER button on the front panel.) active contacts, no external voltage or grounding.
22	IN	
23	OUT	Pin-23 and pin-24 indicate the laser key switch status: Opened - the laser key switch is in the OFF position; Closed - The laser key switch is in the ON or REM position.
24	OUT	

#### 4.4.2 HARDWIRING XP1

64 pin hard wire interface, control signal input and output interface of laser in remote mode. Input high level is greater than 18V valid, input low level is less than 3V valid. Specific interface definitions are shown in Table 7 below.

Table 7XP1 Hardwire interface definitions

No. XP1	Interface requirements		type	description
	Pin	Pin definition		
XP1	A1	Laser request signal	Input signal	Laser request signal, only after this bit is valid will the laser receive other XP1 hard-wired interface input commands.
	A2	Programming mode start-up execution	Input signal	When A8~A14 are all low, it is the laser enable signal; if there is a high level in A8~A14, it enters the programming mode, the program command is executed from the rising edge of A2, and the program number is determined by A8~A14. Users need to ensure that A2 is always high during program execution (B9 is high), and then set A2 low after the program is executed (B9 is low). The laser output power is set by the program if the program number is not 0000000; the laser output power is set by AD analog if the program number is 0000000 and the A6 is high.
	A3	Enabling Internalpatter	Input signal	High level enables PC software control function
	A4	reset signal	Input signal	Active on rising edge; to clear laser alarm bit; effective high-level time at least 1 ms.
	A5	Red light indicator	Input signal	The guide led light indicator is on when A5 is high.
	A6	Simulation control enabling energy	Input signal	When A6 is high, the analog input signal is enabled. The program number Program Number is required to be set to 0, or A8~A14 are all low (non-programming mode).
	A7	Stop programming Mode	Input signal	In programming mode, program execution is terminated immediately when A7 is high.
	A8~A14	Set program Number	Input signal	Hardwired address for selecting a stored program number. A8 is the lowest bit and A14 is the highest bit.
	A15	synchronous input	Input signal	Synchronous input signal, used with the program command WAIT in programming mode.
	A16	COM	Referenc eground	Reference ground for all input signals of XP1.
	C1	Laser-driven power supply	Input signal	The rising edge turns on the main power, and the falling edge turns off the main power.
		C2	Not connect	

C3~C6	Select the optical gate channel	Input signal	C3 is the lowest bit, C6 is the highest bit: 0000-close all optical gate channels; 0001-open channel 1; 0010-open channel 2; 0011-open channel 3. (For lasers with optical gate channels only, these pins are spare in other lasers)
C7	Enable QCW mode	Input signal	Enable QCW mode (For lasers with QCW modes only)
C8~C16	Not connect		
B1	The laser is ready	Output signal	The laser is ready to emit laser light when B1 is high.
B2	Laser output	Output signal	The laser is emitting light when B2 is high.
B3	The laser operates in internal mode	Output signal	The laser works in the internal control mode when B3 is high. In this mode, the laser can be controlled by communication.
B4	Laser anomalies	Output signal	The laser is abnormal when B4 is high.
B5	Laser red light indication	Output signal	The laser is emitting guide light when B5 is high.
B6	AD mode	Output signal	The laser works in the AD mode when B6 is high.
B7	Feedback signal of A1	Output signal	The laser has received the A1 signal when B7 is high.
B8	Main power supply of laser	Output signal	The main power of laser is on when B8 is high.
B9	Program running	Output signal	Laser program is running when B9 is high.
B10	Program ending	Output signal	Laser program is ended when B10 is high. B10 clears when the A2 is invalid.
B11	Abnormal Wave Mode Termination	Output signal	Laser program is ended abnormally when B11 is high. B11 can be cleared when the A4 is high.
B12	Synchronous output	Output signal	Sync signal output in programming mode.

B13	Warning output	Output signal	Laser is warning when B13 is high.
B14	Not connect		
B15	External power supply (Positive pole)	Input signal	The 24 V input voltage, power supply of all XP1 output signal. Only when B15 and B16 access 24 V power, output signal is effective.
B16	External power (Negative pole)	Input signal	Indicate the current optical gate channel: 0000-all optical gate channels closed; 0001-channel1 opened; 0010-channel 2 opened; 0011-channel 3 opened. D1 is the lowest bit, D4 is the highest bit. (For lasers with optical gate channels only, these pins are spare in other lasers)
D1~D4	Current optical gate channel	Output signal	
D5	Not connect		
D6	Not connect		
D7	QCW mode	Output signal	Output signal indicating that the current laser operates in QCW mode (For lasers with QCW mode only)
D8~D11	Laser hardwire address	Output signal	Set the Laser hardwire address (Coding-Cable function): 0000- laser 0; 0001- laser1. D8 is the lowest bit, D11 is the highest bit.
D12~D16	Not connect		

#### 4.4.3 RS232 XP3 Interface

The 9-pin serial interface is used for the communication between the laser and the upper computer. It can be used to communicate with the upper computer of Raycus Company or the software of the upper computer which integrates the communication protocol of Raycus. The definitions are as follows.

Table 8XP3 Serial Interface Definitions

Pin No.	type	Description
2	IN	RXD, Serial port receiving pin of laser
3	OUT	TXD, Serial Sending Foot of Laser
5	COM	GND, Serial port public end

#### 4.4.4 Analog Interface XP4

The analog interface, an 8-core Harting interface, is used to control the output power of the laser by analog in AD mode, and can also monitor the output light and power feedback signals of the laser. The interface definition is shown in Table 9 below.

Table 9 XP4 Analog interface definitions

Pin No.	type	description
1	IN	0~10 V analog signal, laser power control signal in AD mode , 0~10 V corresponding to 0~100% output power
2	AGND	Analog Signal Ground
3	OUT	Power amplifier voltage output. 0 V: 0% laser power output; 8 V: 100% laser power output.
4	Reference	Reference ground for power amplifier voltage
5	OUT	High back-amplification voltage (reserve, no)
6	Reference	Reference Ground for High Backup Voltage

#### 4.4.5 INTERNET Interface XP5

Table 10 XP5 Communication interface definitions.

Pin	Function	Description
1	TX+	Data transmission+
2	TX-	Data transmission-
3	RX+	Data transmission+
4	N/C	connectionless
5	N/C	connectionless
6	RX-	data acceptance-
7	N/C	connectionless
8	N/C	connectionless

#### 4.5. Introduction to Safety Interlock

Raycus" product is designed with a safe interlocking loop, which is a two-channel system with output monitoring and manual reset. When the safety interlocking circuit is open, the safety circuit will disconnect the working power of the optical module, that is, the main power supply of the optical module. To start the main power supply, you must close the two interlocking channels (24 pin interface :17 and 20 feet short ,18 and 19 feet short). Otherwise, the main power will be turned off and the laser cannot be turned on at this time. When one of the channels is open, the laser main power supply is impossible to

start until the other channel is open, and then the two channels are closed before the laser main power supply can be started.

If the interlock is closed (the stop button is also released) and there is no error alarm, press the start (LASER) button to start the main power supply, and the „main power has been started“ pin of the external interface will have a high-level output. When the security interlocking circuit is open or the error is detected, the main power supply of the optical module will be turned off, and the „main power supply has been started“ signal of the interface will become low level. The detected „error state“ is latched and the on-board relay opens the manual reset loop with monitoring until the error is cleared, thus preventing the laser from being restarted. If errors such as short circuit between interlocking channels or short circuit of start (LASER) button are detected, the safety loop cannot be reset before the error is cleared.

#### **4.6. Schematic diagram of the internal electrical circuit of the laser**

The internal electrical circuit of the laser is shown in figure 15:

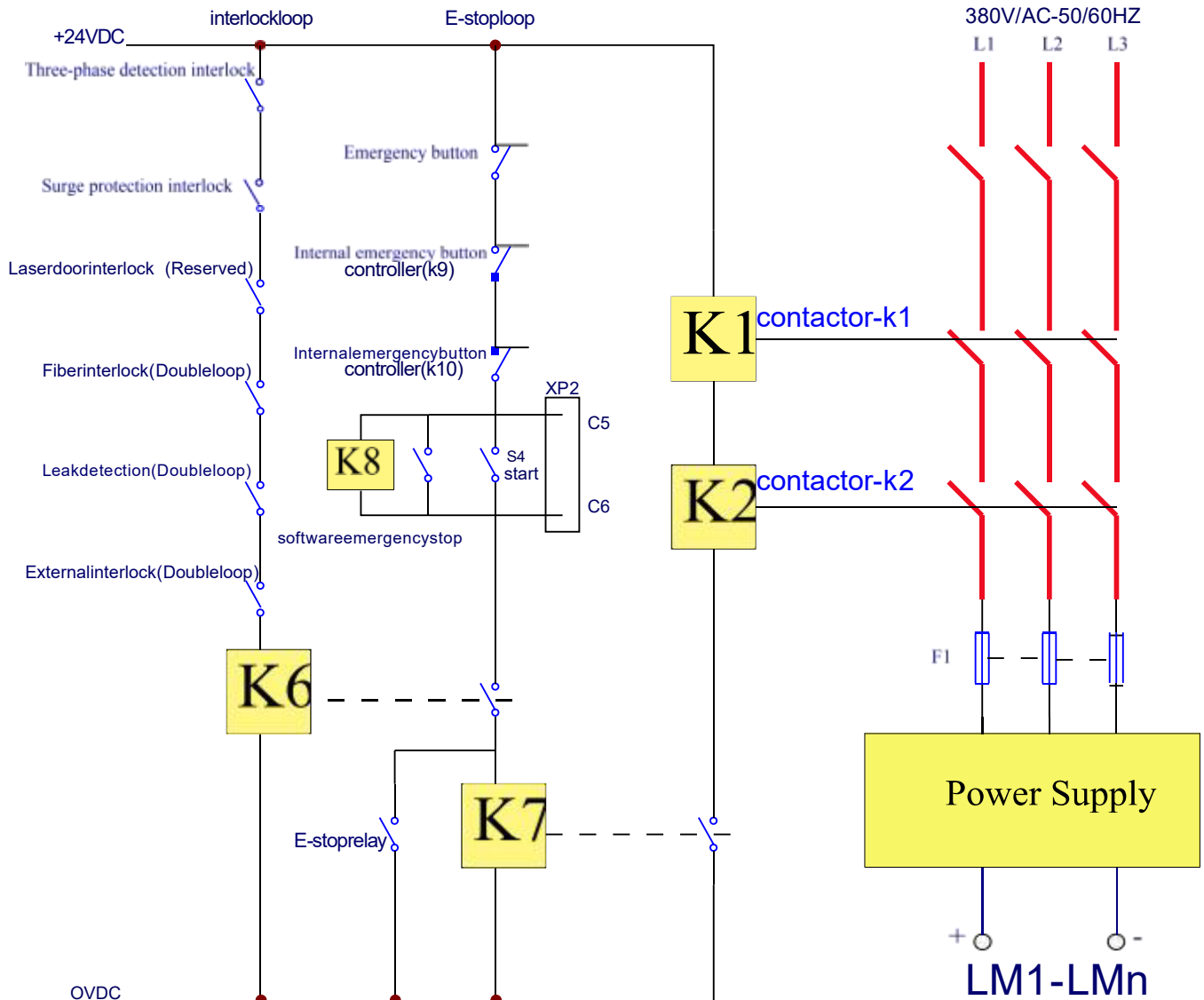

Figure 15 Schematic diagram of the internal electrical circuit of the laser

**Note:** RFL-C20000M-CE laser power control part contactors K1 and K2 are used in parallel with 2 50A and 1 32A contactors, and 6 signal terminals are used in series.

#### 4.7. Start operation sequence

- a) Turn on the water cooler, check whether the water pipe is leaking, turn off the water cooler and connect electrically.
- b) Make sure the circuit breaker is in a OFF state and the stop button on the front panel of the laser EMERGENCY STOP pressed; all electrical connections must be completed before the laser is powered on.
- c) Confirm that the three-phase electrical connection is correct and the power supply meets the specifications of the power supply.

- d) Close the rear panel circuit breaker, release the laser front panel emergency stop switch; turn on the key switch, and the laser has a temperature and humidity alarm, turn off the key switch. After the air conditioner works for 10 minutes, turn on the key switch again. Wait for the air conditioner to continue working for 10 minutes until the temperature and humidity alarm of the laser does not appear, at this time, turn off the key switch and turn on the water cooler; ensure that all laser doors are closed, optical cable output head has been inserted into the cutting head (or corresponding equipment), all interlock interfaces have been closed;
- e) Select the required control mode according to 1.4 control mode, turn on the key switch, start the main power supply waiting for the laser to Ready, the laser Ready, the tricolor green light above the machine, representing that the laser can light.

## 5. Control Mode Selection

The Raycus high-power CW laser has two control modes: namely ON mode and REM mode. Users can select the mode to be entered through the key on the front panel.

Table 11 ON mode and REM mode functions.

	AD Mode	External control	programming mode	Power	Laser ON and off	Red laser
<b>ON Mode</b>	close①	close②	-	communication (13)	communication (11)	communication (12)
	Enable③	close②	-	XP4-1/2 pin pressure	communication (11)	communication (12)
	close①	Enable④	-	communication (13)	XP2-1/2 pin level	communication (12)
	Enable③	Enable④	-	XP4-1/2 pin pressure	XP2-1/2 pin level	communication (12)
<b>REM Mode</b>	close⑤	close⑥	close⑦	communication (13)	communication (11)	communication (12)
	Enable⑧	close⑥	close⑦	XP4-1/2 pin pressure	communication (11)	XP1-A1/A5 is high level
	close⑤	Enable⑨	close⑦	communication (13)	XP1-A1 laser request is high XP1-A2 laser emission enable is high XP2-1/2 input MOD signal	XP1-A1/A5 is high level



Enable⑧	Enable⑨	close⑦	XP4- 1/2 pin pressure	XP1-A1 laser request is high XP1-A2 laser emission enable is high XP2- 1/2 input MOD singal	XP1-A1/A5 is high level
close⑤	Enable⑨	Enable⑩	determined by programming command	XP1-A1 laser request is high XP1-A2 high level indicates operating program	XP1-A1/A5 is high level

① Send "DEC" by communication, or click software;



button on the host computer

② Send "DLE" by communication , or click software;



button on the host computer

③ Send "EEC" by communication , or click software;



button on the host computer

④ Send "ELE" by communication , or click software;



button on the host computer

⑤ XP1-A1 is high level , XP1-A6 is low level or suspending;

⑥ XP1-A1 is high level , XP1-A3 is high level

⑦ XP1-A1 is high level , XP1-A8~A14 is low level or suspending

⑧ XP1-A1 is high level , XP1-A6 is high level

⑨ XP1-A1 is high level , XP1-A3 is low level or suspending

⑩ XP1-A1 is high level , XP1-A8~A14 is not all low level

⑪ Emit laser: Send "EMON" by communication , or click



button on the host computer software

Turn off the laser: Send "EMOFF" by communication , or click



button on the host computer software

- ⑫ Emit red light: Send "ABN" by communication , or click



button on the host computer software

Turn off red light: Send "ABF" by communication , or click



button on the host computer software

- ⑬ The communication sends "SDC XX" to set the power percentage, XX represents the power

percentage, or click

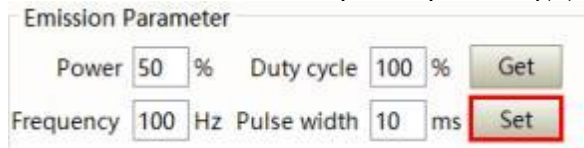

button on the host computer software

### 5.1. ON Mode

In the On Mode, the user can send commands to set different working mode through computer software or direct communication. After the laser is powered on again, the mode before power failure will be memorized.

### 5.2. AD Enable Mode

When AD mode is enabled, the laser power is determined by the analog voltage of pin 1 and pin 4 of XP4. If the AD mode is not enabled, the laser power can be set through the computer software or send the "SDC XX" command.

### 5.3. Emission External Control Enable

When the emission external control is enabled, the laser emission is determined by the level difference between the pins of MOD+, MOD- in the XP2 port; if the emission external control is not enabled, the laser emission or shutdown are determined by the emit button in the Raycus Laser Control System. Also, you can send "EMON" command to turn laser emission on, and send "EMOFF" command to turn laser emission off.

## 5.4. Guide Laser (Red Guide Beam) Control

In “ON” mode guide laser can only be turned on/off by using Raycus Laser Control System, or by sending command of “ABN” (on) / “ABF” (off).

The red light module inside the laser works through communication, so there is a time delay of at least 10ms for the opening and closing of red light;

When the red light is on, the laser cannot be set to “Ready”. Only after the red light is turned off the laser can be set to “Ready”. (This limit can be changed, please contact Raycus Engineer).

## 5.5. Programming Mode

In “ON” mode, when the current program number of the laser is not 0, the laser runs in the “Programming” mode. Please use the Raycus Host Computer Software to edit the waveform and select the pre-run program number.

When the laser is in the internal control mode:

Send the “EMON” command or press the  “ON” button, the laser will start to run the program,

Send the “EMOFF” command or press the  “OFF” button can terminate the laser emission at anytime

When the laser is in the external control mode, the rising edge of MOD starts to operate the program, and the falling edge of MOD can terminate the program at anytime.

## 5.6. REM Mode

### 5.6.1 AD enable mode

When both A1 and A6 of XP1 are set high, the laser operates in AD mode, and the current laser power is determined by the analog voltage of pin 1 and pin 2 of xp4; When A6 of xp1 is set low or suspended, the current laser power is set by sending "SDC XX" command through PC software or communication.

### **5.6.2 Emission external control**

When both A1 and A3 of XP1 are set high, the laser is in the internal control mode, and the laser emission is controlled by the computer software's light on button or through communication sending "EMON" to control the light output, and "EMOFF" to control the light off; When A1 of XP1 is set high, A3 is suspended or set low, the laser is in the external control mode, the output light is determined by the high and low TTL of the MOD signals at A2 (XP1) and pin 1/2 (XP2).

### **5.6.3 Red light control**

When both A1 and A3 of XP1 are set high, the laser is in the red light internal control mode, and the red light is controlled by the computer software red light button or through communication by sending "ABN" or "ABF" command to control the ON/OFF of the red light; When A1 of XP1 is set high, and A3 is suspended or set low, the laser is in external control mode, and the red light is controlled by A5 of XP1

The red-light module in the laser works by means of communication, so there is a time delay of at least 10ms when the red light is turned on and off.

When the red light is on, the laser cannot be set to Ready. Only after the red light is turned off the laser can be set to "Ready". (This limit can be changed, please contact Raycus Engineer).

### **5.6.4 Programming Mode**

When A1 of XP1 is set high and A8-A14 is not 0, the laser is in "Programming Mode". At this time, the laser emission is controlled by A2 of XP1, and the laser emission waveform is determined by the edited waveform.

## 6. Laser Wiring Diagram and Operation Steps

### 6.1. Internal control in ON Mode

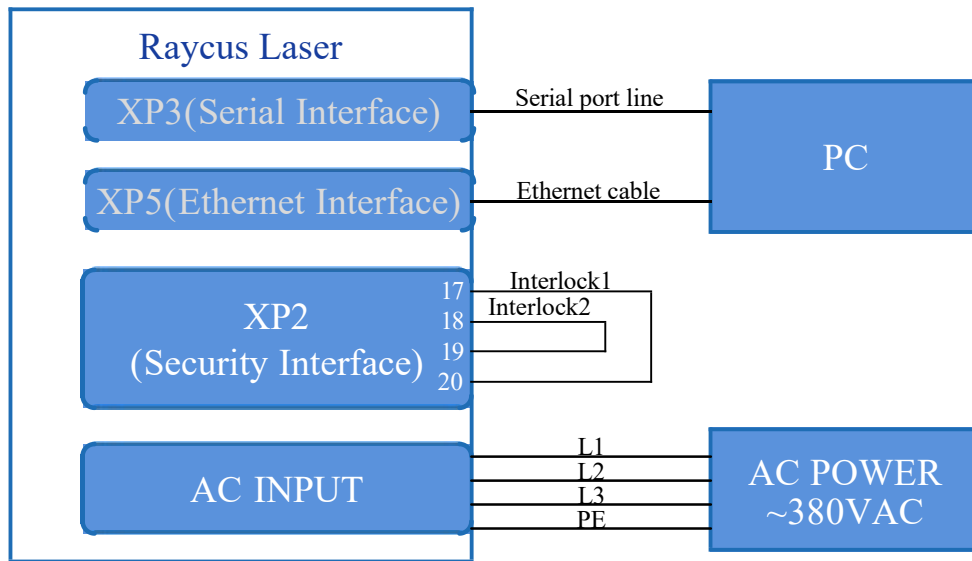

Figure 16 software mode wiring diagram when key switch at “ON” position

#### Operations Steps

- a) Turn the knob switch on the rear panel to “ON”
- b) Turn the key switch to “ON”
- c) Open the Raycus Laser Control System
- d) Click the guide laser “ON” button to view the guide laser
- e) Turn off “AD” mode and turn off external control mode (this mode can be memorized when power off)
- f) Click the main power “ON”
- g) Waiting for “Ready”
- h) Set laser emission parameters
- i) Click the laser “ON”.

## 6.2. Laser Operating in External Control Mode

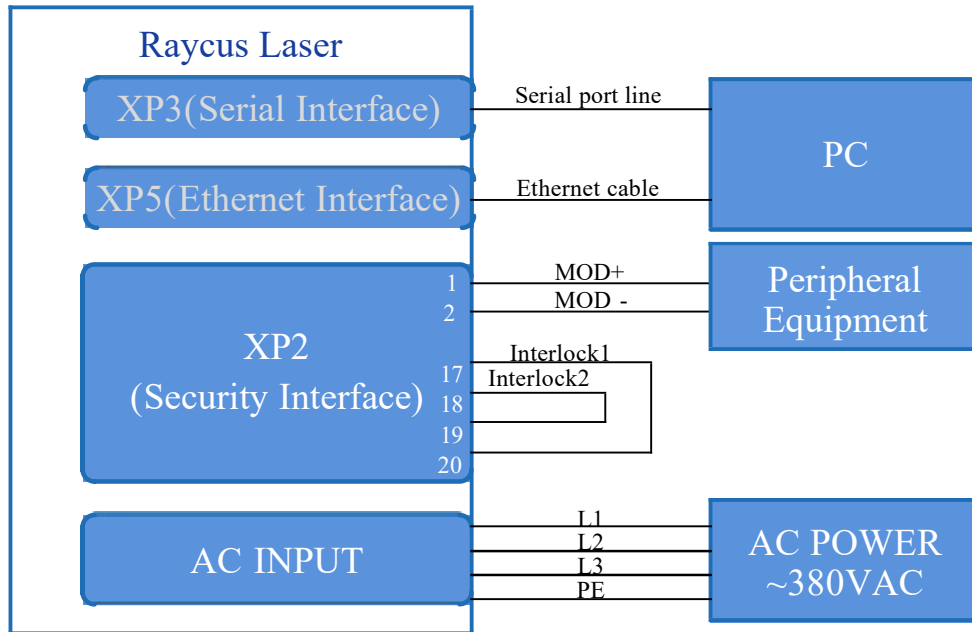

Figure 17 the wiring diagram of laser operating in external control mode

### Operations Steps

- a) Turn the knobswitch on the rear panel to “ON”
- b) Turn the key switch to “ON”
- c) Open the Raycus Laser Control System
- d) Click the guide laser “ON” button to view the guide laser
- e) Turn off “AD” mode and turn on “External Control” mode (this mode can be memorized after power off)
- f) Click the main power “ON”
- g) Waiting for “Ready”
- h) Set the percentage of laser emission power
- i) Turn on the laser through the high level output by MOD signal

### 6.3. In ON Mode, the Laser Emission Power is Externally Controlled by Analog Signal

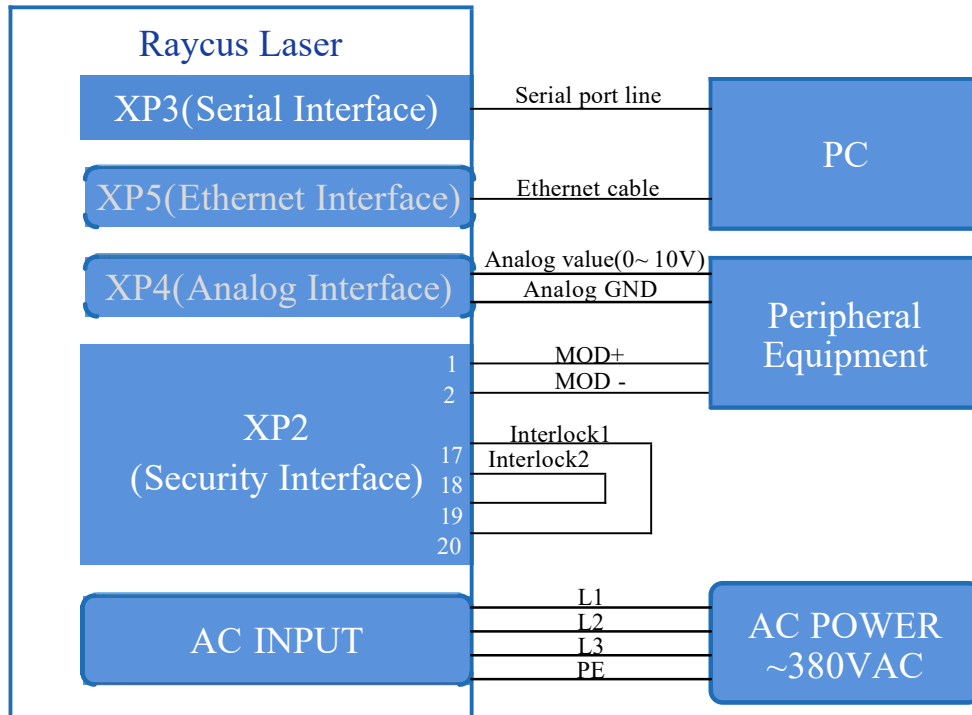

Figure 18 In ON mode, the wiring diagram of the power and laser emission controlled by analog signal

#### Operations Steps

- a) Turn the knob switch on the rear panel to “ON”
- b) Turn the key switch to “ON”
- c) Open the Raycus Laser Control System
- d) Click the guide laser “ON” button to view the guide laser
- e) Turn on the “AD” mode and turn on “External Control” mode (this mode can be memorized after power off)
- f) Click the main power “ON”
- g) Waiting for “Ready”
- h) The control board card outputs power analog and emit control signal.

#### 6.4. Laser Operating in External Control Programming Mode

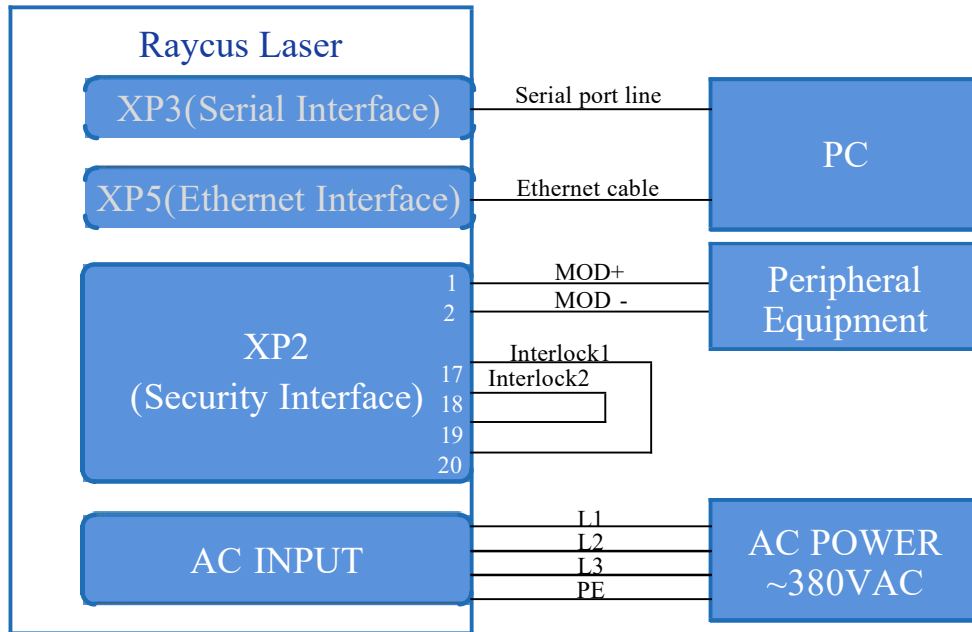

Figure 19 Wiring diagram of external control laser emission in programming mode, in ON mode

##### Operations Steps

- a) Turn the knob switch on the rear panel to “ON”
- b) Turn the key switch to “ON”
- c) Open the Raycus Laser Control System
- d) Click the guide laser “ON” button to view the guide laser
- e) Click the main power “ON”
- f) Waiting for “Ready”
- g) Set the pre-executed waveform number (the program number is greater than 0);
- h) Start waveform at the rising edge of MOD signal.

##### NOTE:

The high-level time of MOD must be greater than the program running time. If MOD gives a falling edge in advance, the Raycus Laser Control System will display that the laser program is abnormally terminated.



### 6.5. Set the Power Analog Quantity in REM Mode to Control the Laser Emission

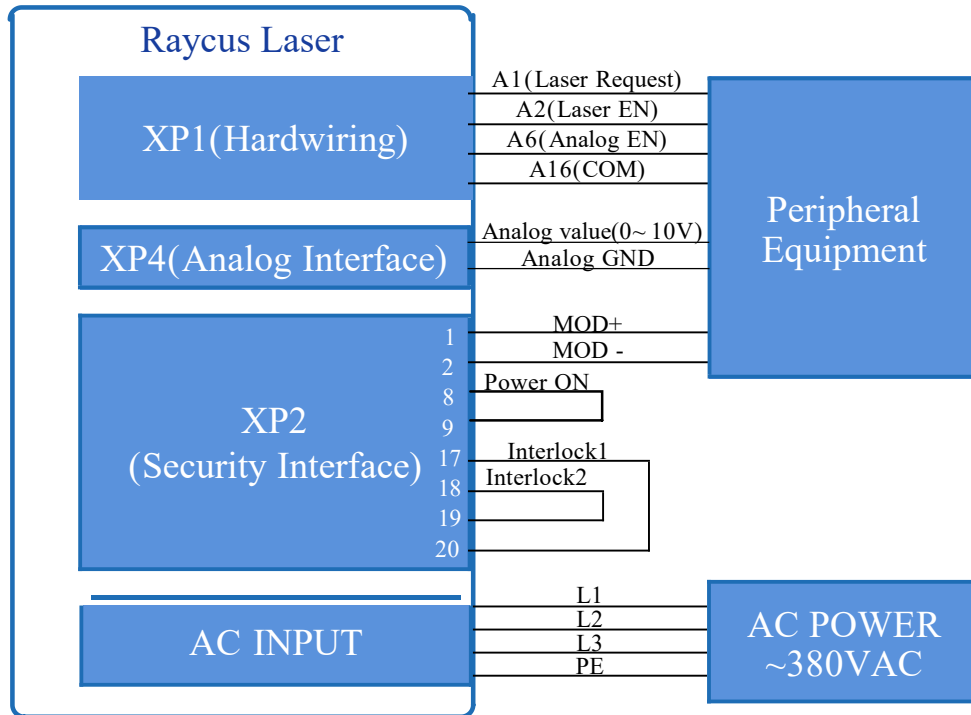

Figure 20 REM mode power and laser emission are externally controlled wiring diagram

#### Operations Steps

- Turn the knob switch on the rear panel to “ON”
- Turn the key switch to “REM”
- Short-circuit pin 8/9 on XP2
- XP1-A1 connects to 24V, XP1-A6 connects to 24V
- Connect XP1-A5 to 24V and turn on the guide laser; after checking the optics, connect XP1-A5 to 0V and turn off the guide laser
- XP1-C1 is connected to 24V, and the main power is turned on (operator can also directly press the LASER button, or the host computer software clicks the main power “ON”);
- Waiting for “Ready”;
- XP1-A2 connects to 24V, and the control board outputs analog and MOD signals

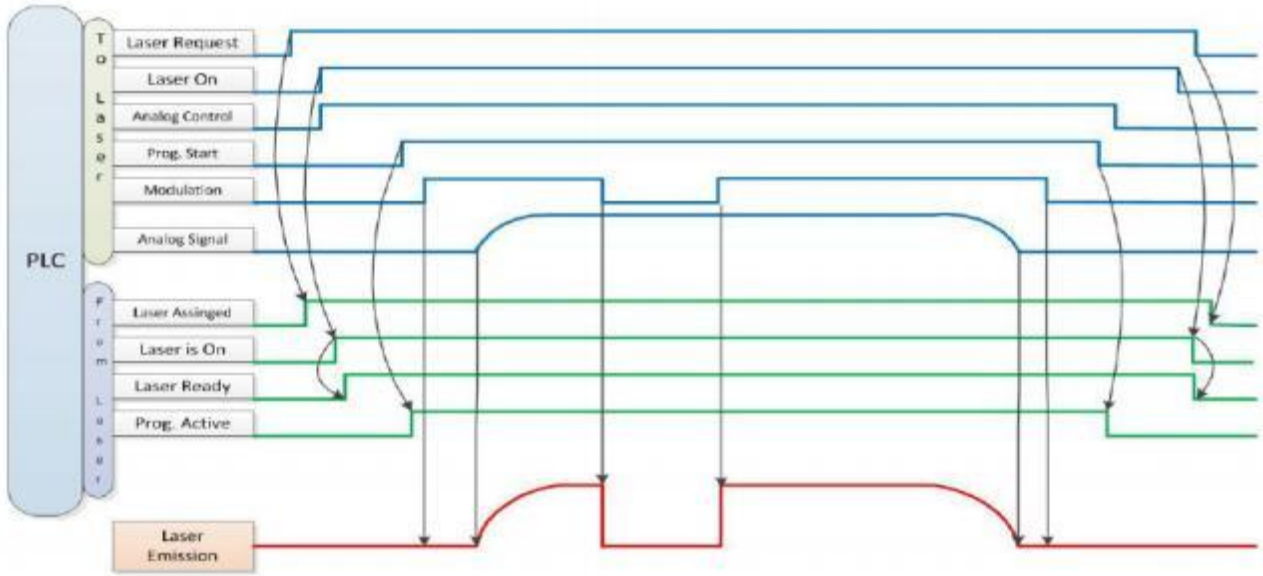

Figure 21 Timing diagram

### 6.6. Power Communication Setting in REM

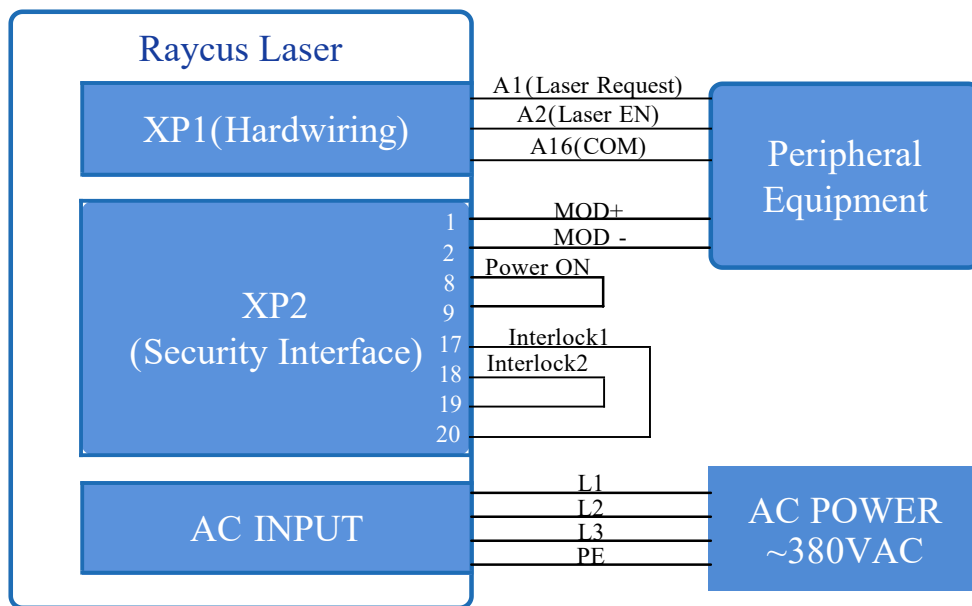

Figure 22 Wiring diagram of power internal control and laser emission external

**Operations Steps:**

- a) Turn the knob switch on the rear panel to“ON”
- b)Turn the key switch to“REM”
- c) Short-circuit pin 8/9 on XP2
- d)XP1-A1 connects to 24V
- e) Connect XP1-A5 to 24V and turn on the guide laser; after checking the optics, connect XP1-A5 to 0V and turn off the guide laser
- f)XP1-C1 is connected to 24V, and the main power is turned on (users can also directly press the “LASER” button, or the host computer software clicks the main power “ON”)
- g)Waiting for “Ready”
- h)The Raycus Laser Control System sets the power, XP1-A2 is connected to 24V, and the control board card outputs MOD signal

**6.7. Programming Mode in REM Mode**

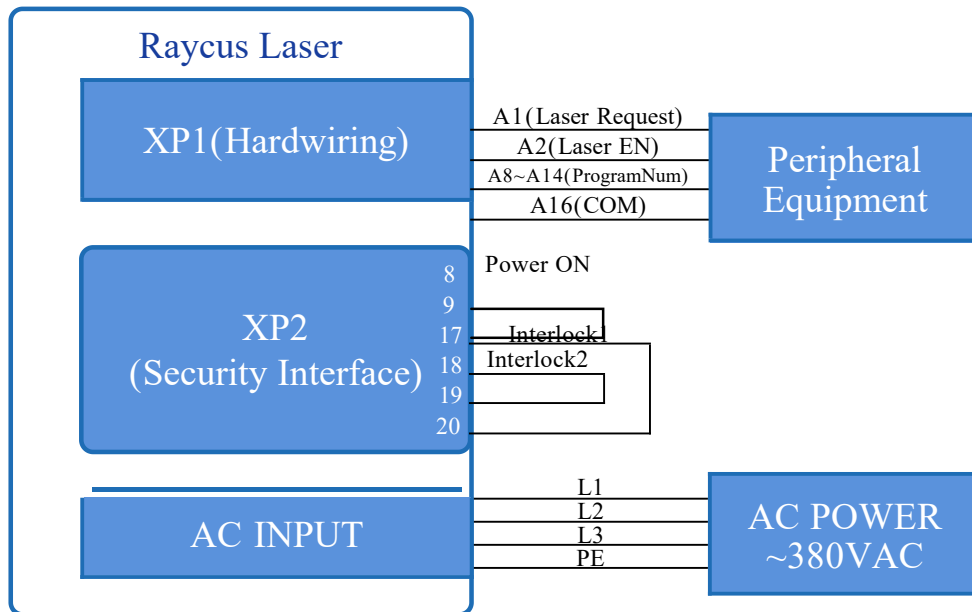

Figure 23Wiring diagram of programming mode in REM Mode

### Operations Steps:

- a) Turn the knob switch on the rear panel to“ON”
- b) Turn the key switch to“REM”
- c) Short-circuit pin 8/9 on XP2
- d) XP1-A1 connects to 24V
- e) Connect XP1-A5 to 24V and turn on the guide laser; after checking the optics, connect XP1-A5 to 0V and turn off the guide laser
- f) XP1-C1 is connected to 24V, and the main power is turned on (users can also directly press the “LASER” button, or the host computer software clicks the main power “ON”)
- g) Waiting for “Ready”
- h) XP1-(A8- 14) select the number of the pre-executed program, set XP1-A2 high to start executing the program.

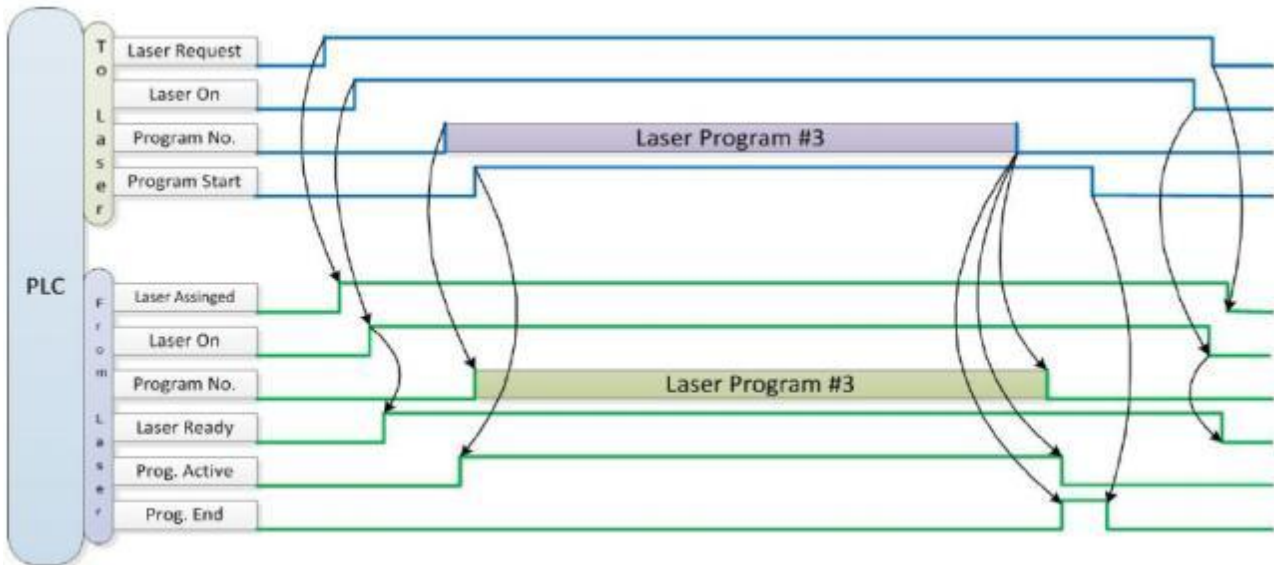

Figure 24 Timing diagram

## 7. RS232 and INTERNET communication command

### 7.1. Port Configuration

RS-232 configuration is as follows:

baud rate :9600, data bit :8, stop bit :1, no parity bit and no control flow.

Ethernet port is configured as follows:

Default laser IP address :192.168.0.10

Laser port :10001

## 7.2. Laser Communication Protocol (Network Port & Serial Port)

All commands and return values in this Agreement are composed of ASCII characters. Note the following points when entering :

- a) Commands generally consist of three or four letters, sometimes with additional values.
- b) All commands and return values end with the enter character (CR,0x0D, \r. If this product receives a string with a „enter“ character but the command is invalid, the Command Err! is returned r".
- c) For easy identification, all commands are capital letters, but in fact this product is not case-sensitive. To facilitate identification, add a space between the command and the parameter.
- d) This product sends a return value for each command received. The return value generally contains the command content itself. If the returned content contains a numeric value or contains an error type, the returned command content is separated from the numeric value or from the error type.

The specific agreement content and command examples of this product are shown in Table 12.

Table 12 Specific Protocol Contents and Command Examples of Laser

Command	Description	Command example
ABF	Aiming Beam OFF –Turn off red	Send: „ABF\r“ Return: „ABF\r“
ABN	Aiming Beam ON – Turn on red	Send: „ABN\r“ Return: „ABN\r“
DEABC	Disable External Aiming Beam Control	Send: „DEABC\r“ Return: „DEABC\r“
EEABC	Enable External Aiming Beam Control	Send: „EEABC\r“ Return: „EEABC\r“
DEC	Disable External Control	Send: „DEC\r“ Return: „DEC\r“
EEC	Enable External Control	Send: „EEC\r“ Return: „EEC\r“
DLE	Disable Hardware Emission Control	Send: „DLE\r“ Return: „DLE\r“
ELE	EnableHardwareEmissionControl	Send: „ELE\r“ Return: „ELE\r“
EM OFF	Stop Emission	Send: „EMOFF\r“ Return: „EMOFF\r“
EMON	Start Emission	Send: „EMON\r“ Return: „EMON\r“
MPWR OFF	Main Power OFF	Send: „MPWROFF\r“ Return: „MPWROFF\r“
MPWR ON	Main Power ON	Send: „MPWRON\r“ Return: „MPWRON\r“

SPW	Set Pulse Width	Send: „SPW 100\r“ Return: „SPW:100\r“ (Set pulse width as 100ms) Other return values: „ERR: input Err\r“ (Input pulse width <0.0001) „ERR: Out of Range\r“ (Over maximum pulse width) „ERR: Duty Cycle too High\r“ „ERR: Duty Cycle too Low\r“ „SPW:100, Duty=100%\r“
SPRR	Set Pulse Repetition Rate	Send: „SPRR 1000\r“ Return: „SPRR: 1000\r“ „ERR: input Err\r“ „ERR: Out of Range\r“ „ERR: Duty Cycle too High\r“ „ERR: Duty Cycle too Low\r“ „SPW: 100, Duty=100%\r“
SDC	Set Diode Current (%) The set value must be less than 100% and above the minimum current setting value, which can be set to 0. If the set value is greater than 100, the default is input 100.	Send: „SDC 100\r“ Return: „SDC: 100\r“ Other return values: „ERR: Input Err\r“ „Laser is worked in AD Mode\r“
RCS	Read Current Setpoint	Send: „RCS\r“ Return: „RCS: 56.7\r“ (The current set value is 56.7 %)
RPRR	Read Pulse Repetition Rate (Hz)	Send: „RPRR\r“ Return: „RPRR:10\r“ (Repeat frequency is 10Hz)
RBT	Read Board Temperature	Send: „RBT\r“ Return: „RBT:36.6\r“
RPW	Read Pulse Width (ms)	Send: „RPW\r“ Return: „RPW:5.5\r“ (pulse width is 5.5ms)
RCT	Read Laser Temperature	Send: „RCT\r“ Return: „RCT:34.5\r“
PERR	Reset Errors	Send: „PERR\r“ Return: „PERR\r“
SUT	Set Up Time (ms)	Send: „SUT 50\r“ Return: „SUT:50\r“

SDT	Set Down Time (ms)	Send: „SDT 50\r“ Return: „SDT:50\r“
RUT	Read Up Time (ms)	Send: „RUT\r“ Return: „RUT:50\r“
RDT	Read Down Time(ms)	Send: „RDT\r“ Return: „RDT:50\r“
PSRT	Program Start	Send: „PSRT 1\r“ Return: „PSRT:1\r“
PSTP	Program Stop	Send: „PSTP\r“ Return: „PSTP\r“
ECM	Enable Calibration Mode –Power linear correction mode (in this mode, the external analog is corrected and output after filtering, so the response time of AD analog is larger than that of through mode)	Send: „ECM\r“ Return: „ECM\r“
DCM	Disable Calibration Mode (AD analog response time is less than 100 us in this mode)	Send: „DCM\r“ Return: „DCM\r“
Others	Command error	Send: „BGM\r“ Return: „Command Err!\r“
STA	Read device status – Read the product status. A return value of 32-Bit digital information. The meaning of each Bit is as follows (undefined or „reserved“ Bit negligible):	
	Bit 0	normal operation
		Authorization time
	Bit 1	normal
		Temperature too high
	Bit 2	Emission Off
		Emission On or in preparation
	Bit 3	No high reflection
High reflection Abnormal		
Bit 4	External AD mode=off	
	External AD mode=on	
Bit 5	Power Correction Mode=off	
		Send: „STA“ Return: „STA:4100“ returned value 4100(Decimal) can be converted to 0 x1004 (hexadecimal), and then converted to binary to see that Bits2 and 12 have been set. The laser enable is on and the modulation mode is enabled

		Power Correction Mode=on
Bit 6		normal
		Sub-controlling communication abnormal
Bit 7		Normal
		Sub-modual abnormal
Bit 8		Guide red light=off
		Guide red light=on
Bit 9		The laser is not ready
		The laser is ready
Bit 10		QCW mode=off
		QCW mode=on
Bit 11		Module Main Power=off
		Module Main Power=on
Bit 12		Modulation mode=off
		Modulation mode=on
Bit 13		normal
		Leakage sensors 1 leaking
Bit 14		normal
		Leakage sensors 2 leaking
Bit 15		No laser
		Laser is power on
Bit 16		Gate mode=off
		Gate mode=on
Bit 17		AC input normal
		AC input abnormal
Bit 18		external Emission control=off
		external Emission control=on
Bit 19		normal
		Laser fault
Bit 20		Slow up slow down mode off
		Slow up slow down mode on
Bit 21		A laser operates in ON" mode
		A laser operates in REM" mode



Bit 22	Wave mode off
	Wave mode on
Bit 23	Surge protector normal
	Serge protector failure
Bit 24	normal
	Low temperature fault
Bit 25	normal
	Humidity alarm
Bit 26	normal
	Water flowmeter 1 Flow Alarm
Bit 27	Red light internal control
	Red Light External Control
Bit 28	normal
	Water flowmeter 2 Flow Alarm
Bit 29	normal
	Module locked
Bit 30	Optical circuit safety interlock normal
	Optical circuit safety interlock abnormal
Bit 31	normal
	High average power

## 8. PC software instructions

PC software download address: <http://www.raycuslaser.com/list/56.html>

### 8.1. Maininterface of PC software

The PC software's main interface shows as Figure 25.



Figure 25PC software display main interface

## 8.2. Multi-laser control area

Multi-laser control area is as Figure 26

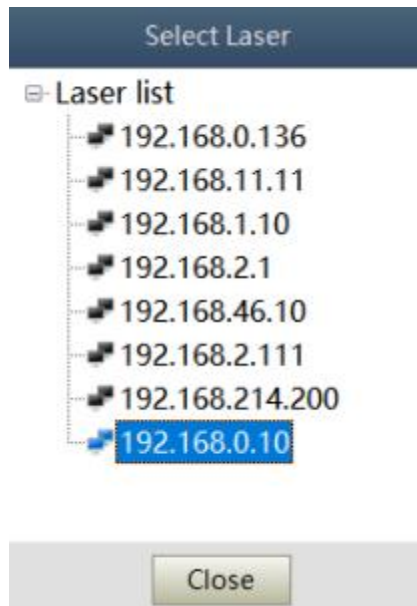

Figure 26Multi-laser control area interface

Select IP address of corresponding laser, then double click. PC software will take communication with selected laser. After the communication established, the lower left status display shows that the network connection is ok, as Figure 27.



Figure 27 communication status interface between PC software and laser

### 8.2.1 Add/delete laser

You can add/delete laser in the laser list area by right-click to add/delete In the PC software. You need to type the IP address of laser to add a new laser. Detailed operation is shown in Figure 30.

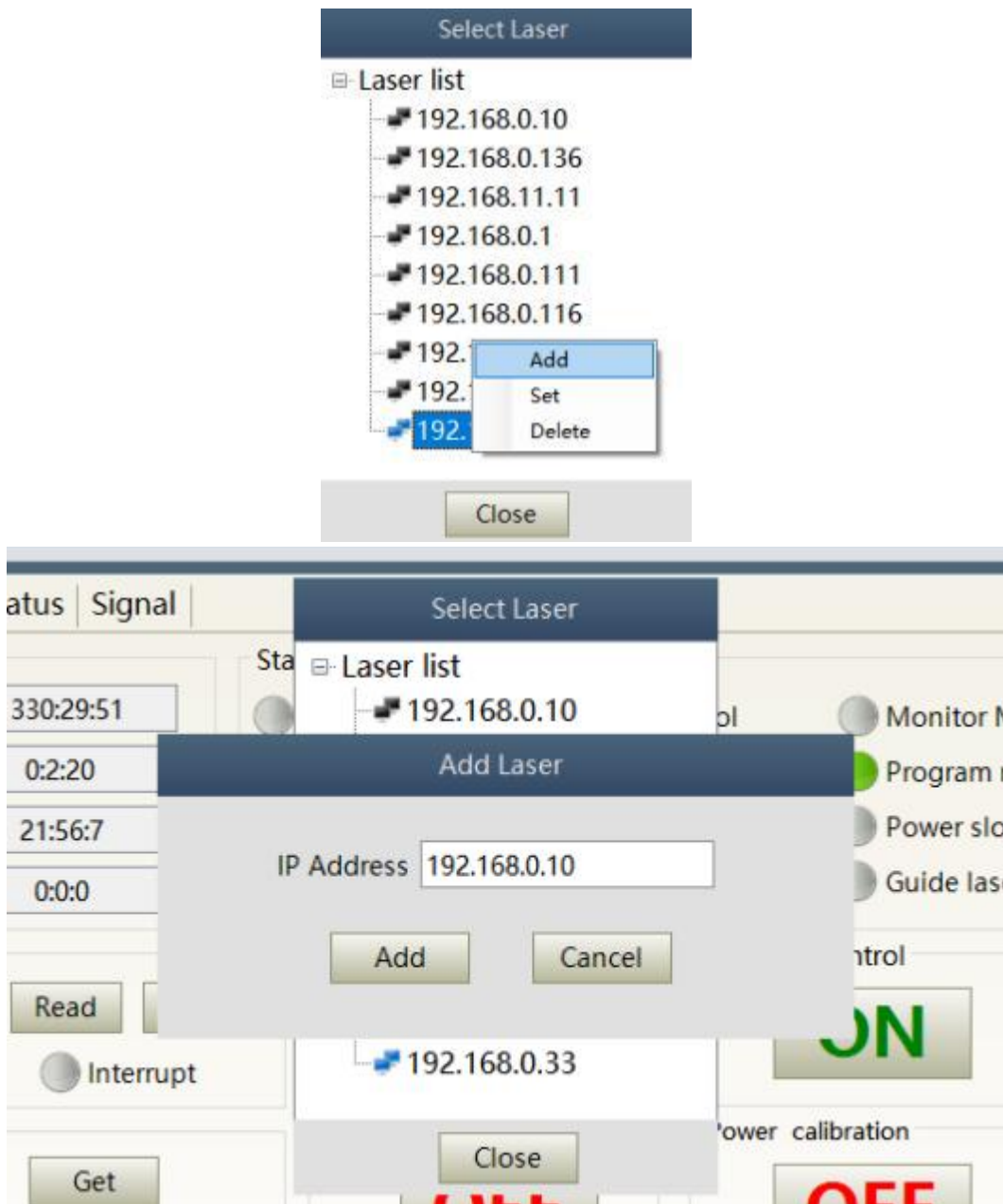

Figure 28 Procedure for adding a laser to the PC software

### 8.2.2 Modify laser IP

After the laser connection has established, select the IP address of current laser and right-click to set it up as Figure 29.

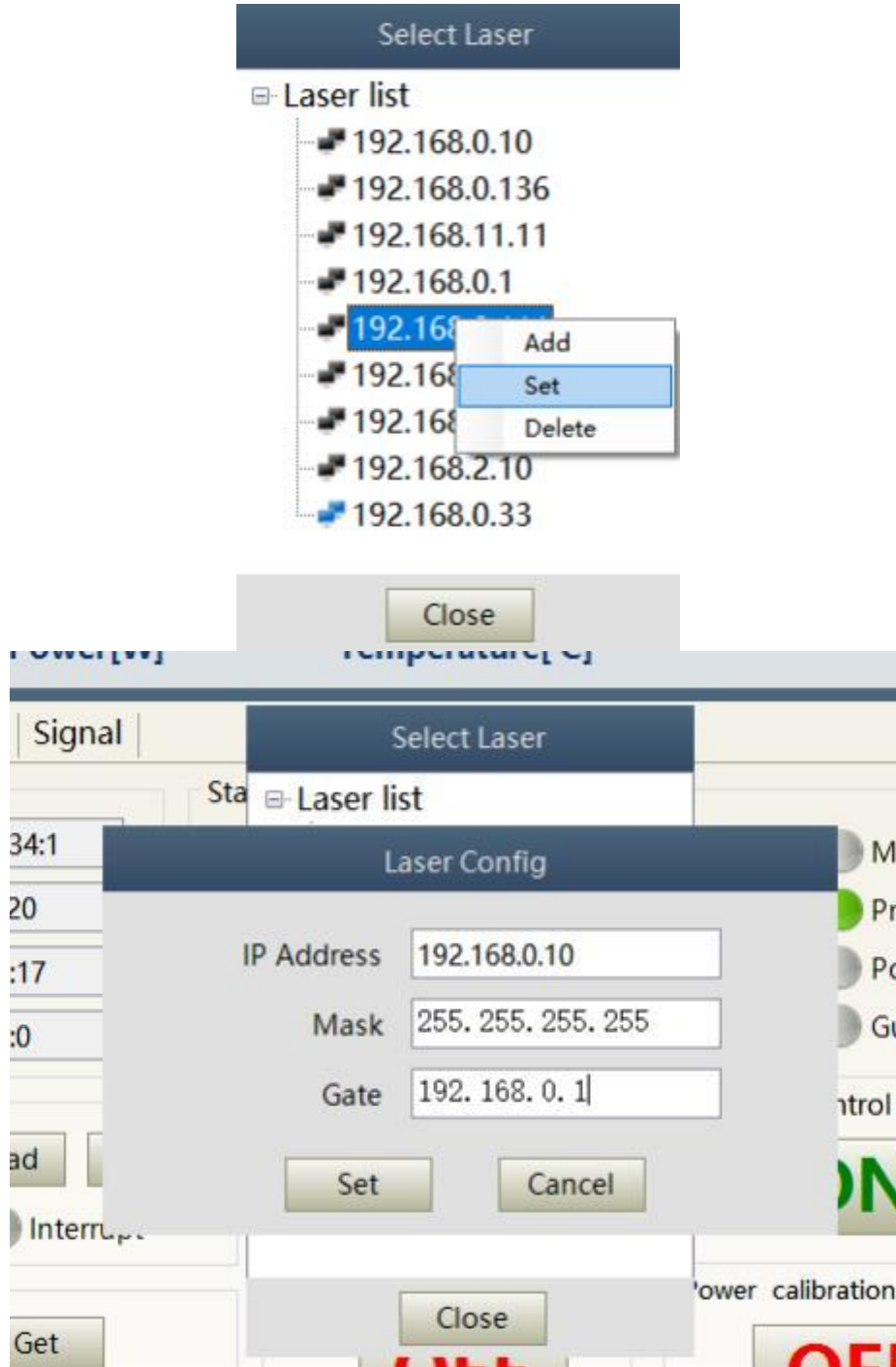

Figure 29 Modify the IP address of laser

### 8.3. Main working status display

The laser's main status display is as Figure 30, Table 13.



Figure 30A diagram of the laser's main display area

Table 13 The laser main display content and meaning

Display	Meaning
Output power	current setting percentage of power in realtime
Output power	Average laser output power in realtime (W)
Laser temperature	Water cooling temperature in realtime (°C)
Power light	Status of main power supply: green-main power supply is on, gray-main power supply is off
Ready light	Indicates readiness of current laser: green-laser is ready, gray-laser is not ready
Alarm light	indicates alarm status of current laser: yellow- laser is abnormal, gray-laser is normal
Emission light	indicates the working model of the current laser: red-laser is in working model gray-laser is not in output model

### 8.3.1 Laser's cumulative operating time display area

The laser's cumulative operating time display is shown in Figure 31. The cumulative start-up time, cumulative laser output time, today's power-on time and today's lighting time can be displayed in hours, minutes and seconds respectively.

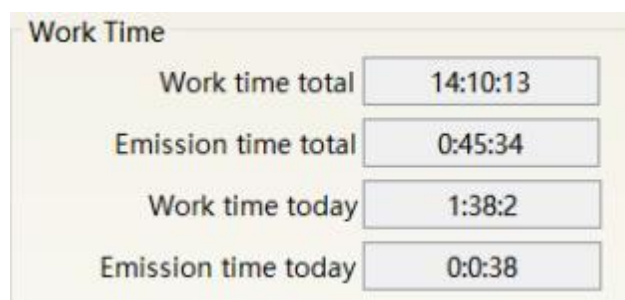

Figure 31 Laser cumulative operating time display interface

### 8.3.2 Laser working status display area

The laser working status display area is as Figure 32, Table 14.



Figure 32A diagram of the laser's working status display area

Table 14 The laser main display area clarification

Display	Content explanation
Emergency stop	Red: emergency stop button on front panel is pressed Gray: emergency stop button is reset
REM	Green: laser works in REM mode Gray: laser works in ON mode
Red laser external control	Green: laser works in red laser external control mode Gray: laser works in red laser internal mode. Laser on/off controllable by software
Red laser	Green: red laser is on Gray: red laser is off
Output fiber Interlock status	Green: Interlock spot at output fiber end is make Gray: Interlock spot at output fiber end is break
External control model	Green: Laser works in external control mode Gray: laser works in internal control mode. Laser on/off is controllable by software
Power correction	Green: Laser operates in power linear correction mode, in which control system automatically adjusts the laser's output power. It makes the output power linear, with a longer response time for AD analog in this mode, longer than 1mS. Gray: laser operates in non-correction mode, and the external 0-10V analog voltage is linear only with the current of the pump auxiliary tube. The response time for this mode AD simulation is less than 100uS
AD model	Green: Laser power is determined by the 0-10V analog voltage on XP4 when laser works in AD mode. Gray: laser power is set by PC software or communication commands.
Monitoring model	Green: PC software is in monitoring mode. User can monitor laser status only, but not able to take control of laser. Monitoring model is activated when interface 10001 of laser occupied. Gray: PC software operate in normal mode
InterLock1 make	Green: XP2 leg 17,18 on safety interface make Gray: XP2 leg 17,18 on safety interface break
InterLock2 make	Green: XP2 leg 19,20 on safety interface make Gray: XP2 leg 19,20 on safety interface break
Programming model	Green: Laser is in program mode Gray: Laser is not in program mode
Power slow rise & fallmode	Green: laser works in power slow rise & fall mode Gray: laser does not work in power slow rise & fall mode

### 8.3.3 Laser power-up, mode selection, light-out control area

Laser power-up, mode selection, light out control display area is as in Figure 33, the display content is as in Table 15.



Figure 33 Laser power-on, mode selection, light out control display area

Table 15 Laser power-on, mode selection, light out control display area explanation

Display	explanation
Main power button	Click ON, main power on; click OFF, main power off
External control mode	Click ON, activate laser external control; Click OFF, shut laser external control; mode power-off memory automatically
AD mode	Click ON, AD analog mode on; click OFF, AD analog mode off; mode power-off memory automatically
Red guide beam	Click ON, red guide beam on; click OFF, red guide beam off
Power correction	Click ON, activate laser power correction mode; click OFF, shut laser power correction mode; mode power-off memory automatically
Eliminate alarm	Eliminate current laser alarm
Laser ON	Laser is in output
Laser OFF	Laser is off

### 8.3.4 Programming mode test area

The laser programming mode test area interface is as Figure 36, in which the „START“ button is used to test the programming of the programming mode. This function can only run internal mode (when external mode is turned off). Enter the current pre-tested programming number in the digital text box and click the START button.



Figure 34 Laser programming mode test area display interface

### 8.3.5 Power slow rise&down parameters setting area

The interface of the laser power slow rise & fall parameter setting area is as Figure 35. Click „read parameter“ to read the power rise and fall times stored in the laser. Click „setting parameters“ to set a new power rise and fall time. When the rise and fall times are set to 0, the power slow rise & fall function is automatically switched off. When there is no 0, the slow rise or fall function is automatically turned on.

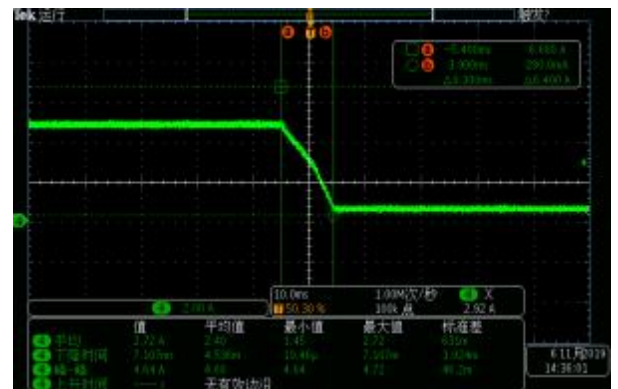
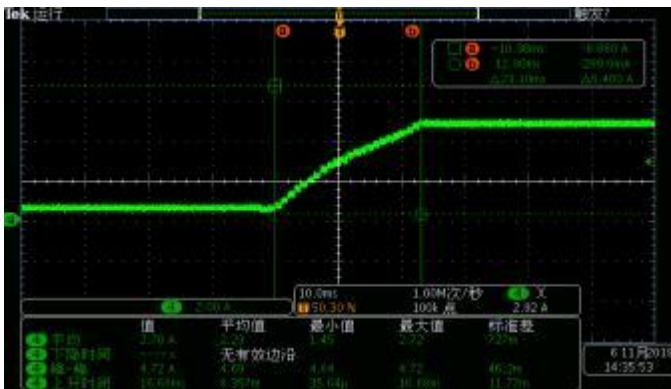
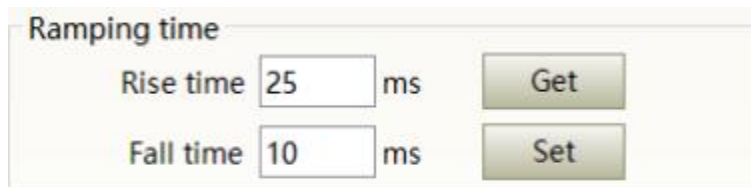

Figure 35 The power slow rise and fall setting area interface and measured programmings

### 8.3.6 Laser output parameters read the settings area

Laser output parameter setting interface is as Figure 36. The output parameter setting is not valid when AD mode is on.



Figure 36 Laser output parameter setting area display interface



### 8.4. Laserparameterdisplayarea

The display interface for laser parameter display area is as Figure 37. The module status is used to shield the faulty module, the green light indicates the number of modules installed inside the current laser, and the check box indicates the module that is actually running in the current laser.

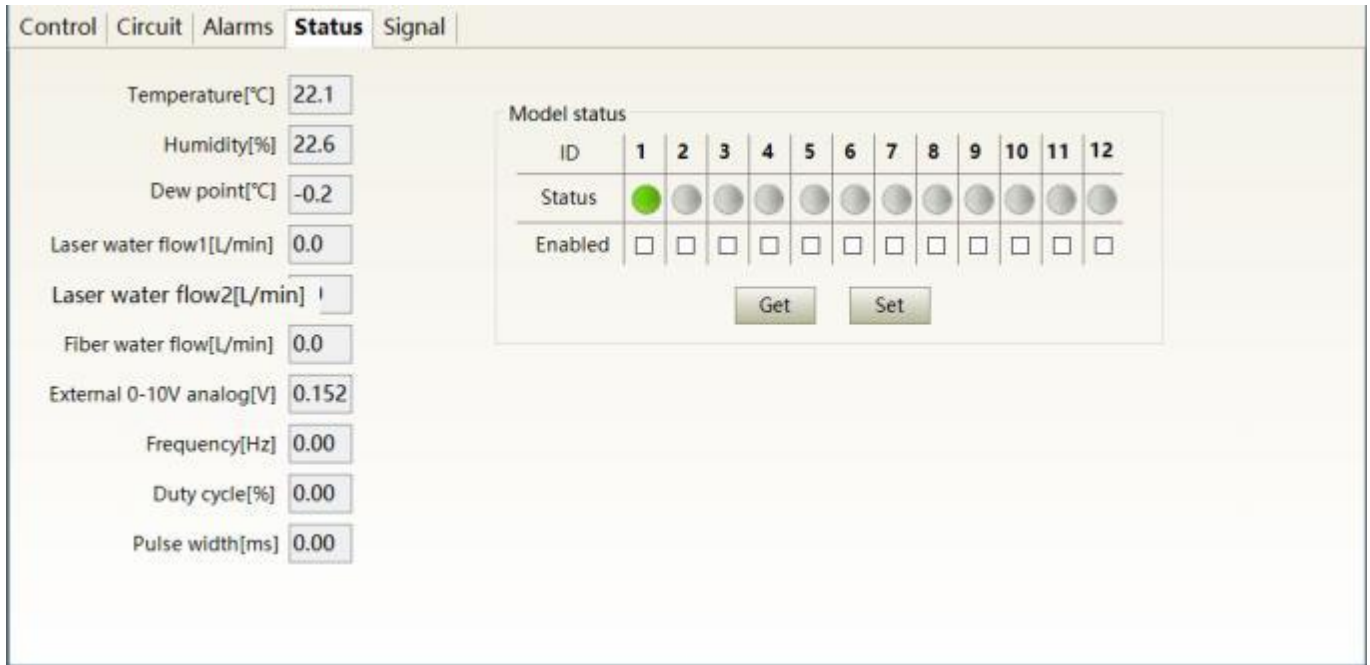

Figure 37 Laser parameter display area display interface

### 8.5. Alarm type display area

The laser alarm type display area interface is as Figure 38. This interface shows the cause of the alarm for the current laser.



Figure 38 Laser alarm type display area interface

### 8.6. PC softwareoperatingmodeselection

The laser operating mode is set by the PC software. Its operating interface is as Figure 39. The interpretation of the various patterns can be found in Table 16. The programming editing interface is displayed on the software only when programming mode is selected.

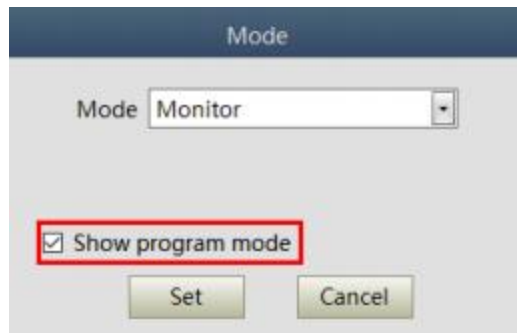
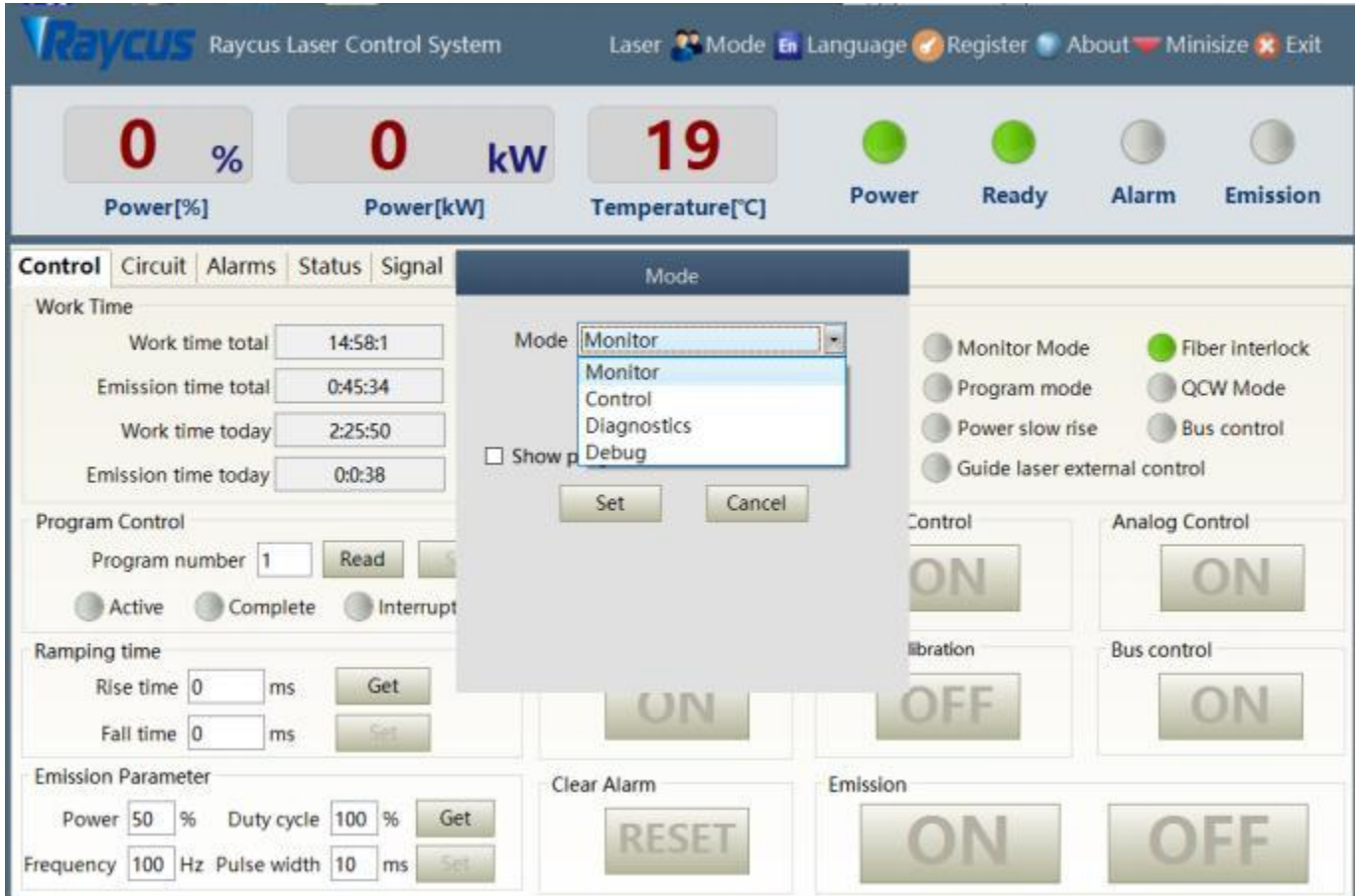

Figure 39 Laser operating mode selects the display area interface

Table 16 Laser operating mode and explanation

Mode selection	Mode explanation
Monitor	A concise software interface, which can monitor basic status information
Control	Supports the selection of control modes, such as AD mode, external control mode, and programming mode
Diagnostics	Displays laser's all status and parameters for diagnosis purposes
Debug	You can modify laser parameters(subject to valid password)

### 8.7. Language Displays laser’s all status and parameters for diagnosis purposes

Laser’s language selection interface is as figure 40. User can choose between Chinese simplified and English by click „setting language“. Setting effective after PC software restarted.



Figure 40 Language selection interface

### 8.8. Authorization (time-limited locking)

#### 8.8.1 Authorization in user mode

The authorization settings in user mode are as Figure 41. Laser can be locked and unlocked by valid authorization code.

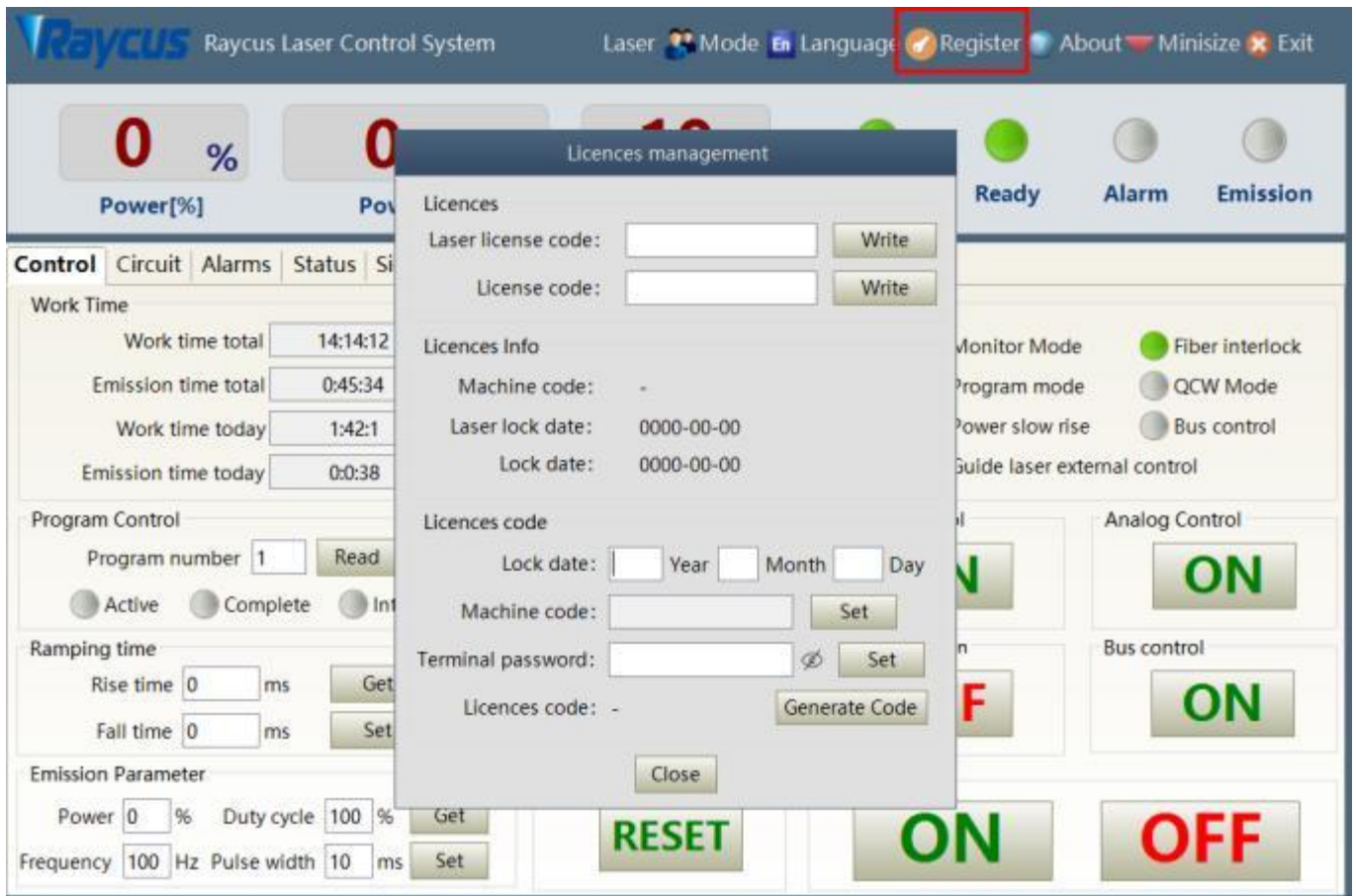

Figure 41 The authorization settings operating interface in user mode

### 8.8.2 Authorization in authorization mode

The authorization settings in laser authorization mode are as Figure 42. This interface allows the customer to lock and unlock the machine and can also be used as an authorization code generator.

- a) The locking time setting can set the effective using time of laser. For example, the locking time: May 21, 2020, indicating that the laser is locked until 0:00 on May 21, 2020. 0/0/2000 means the laser is permanently unlocked.
- b) The terminal password is set for the laser locking party. The terminal code can only be set once, and no modification is allowed after its set. The terminal password is 8-byte here, e.g. 0123456789ABCDEF, no other characters are allowed.
- c) The software automatically calculates the authorization code when user click to generate an authorization code. Laser's limited time lock is achieved when user click again to set the authorization time.

Licences management

Licences

Laser license code:  Write

License code:  Write

Licences Info

Machine code: 0

Laser lock date: 2036-12-8

Lock date: not configured

Licences code

Lock date:  Year  Month  Day

Machine code:  Set

Terminal password:  Set

Licences code: - Generate Code

Close

Figure 42 Authorization settings operating interface in authorization mode

## 8.9. About

Laser relevant information such as date of manufacture, model, serial number, controlling serial number, token version number, system information and other information can be queried in the PC software „about“ item. Specific interface is as Figure 43.

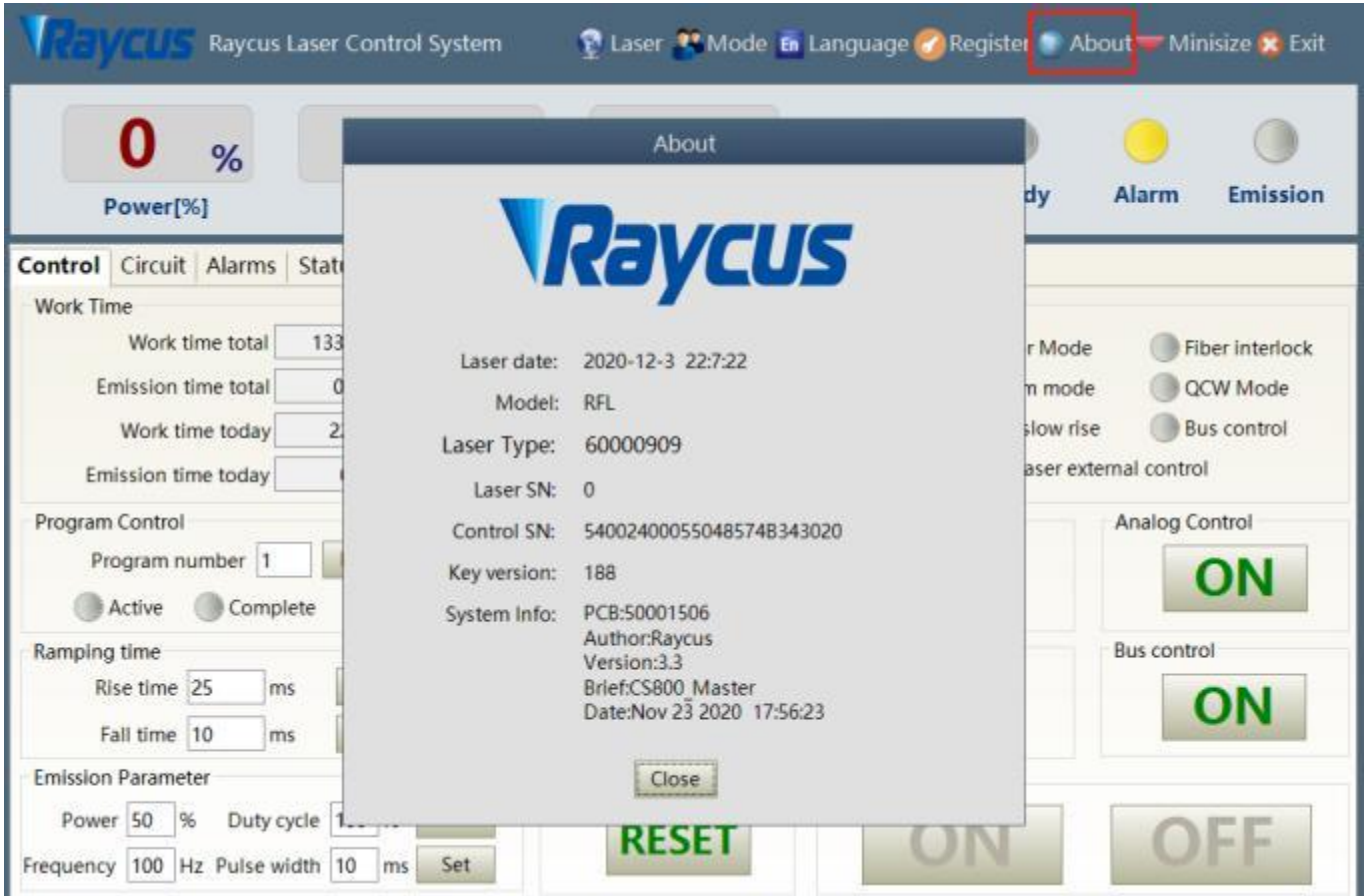

Figure 43 Laser relevant information query interface

### 8.10. XP1 interface status indication (in diagnostic mode)

The laser interface status indicator interface is as Figure 44. It is convenient to view the interface status information which represents the input and output status of the XP1 interface on the back panel.



Figure 44 The interface status in diagnostic mode

### 8.11. Log (in diagnostic mode)

Laser's working log interface is as Figure 45. User can query work log by entering the time to query and click on the „search“ button.

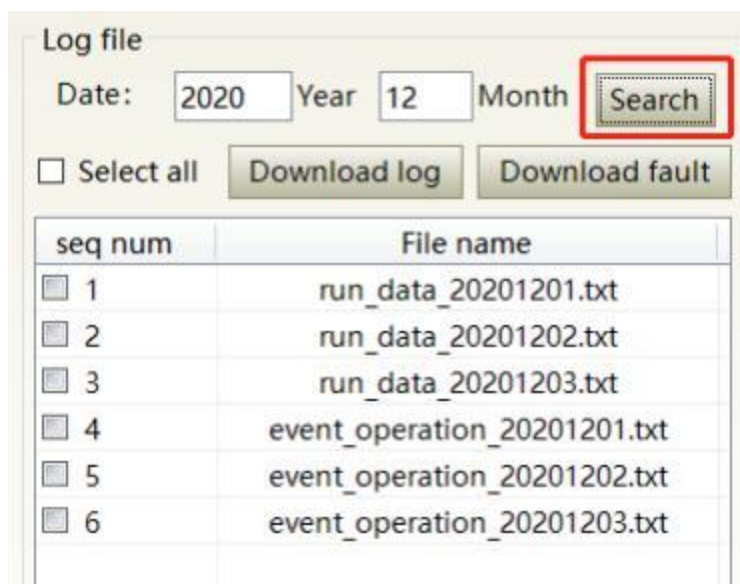

Figure 45 Laser's working log interface

### 8.11.1 Download log

Log download interface is as Figure 46.

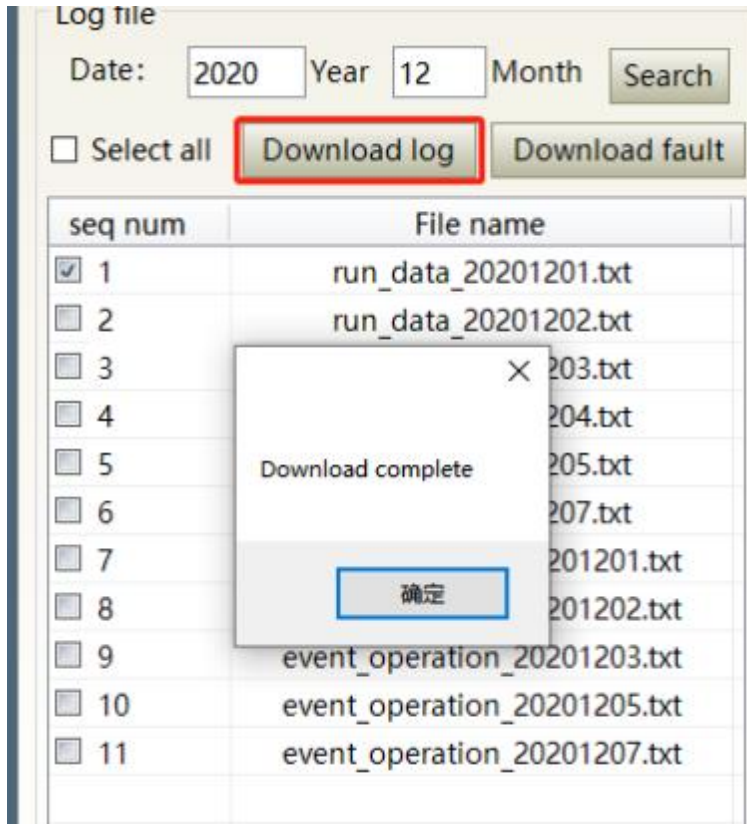

Figure 46 Log download interface

### 8.11.2 Download record of historical fault

Historical fault record download interface is as Figure 47.

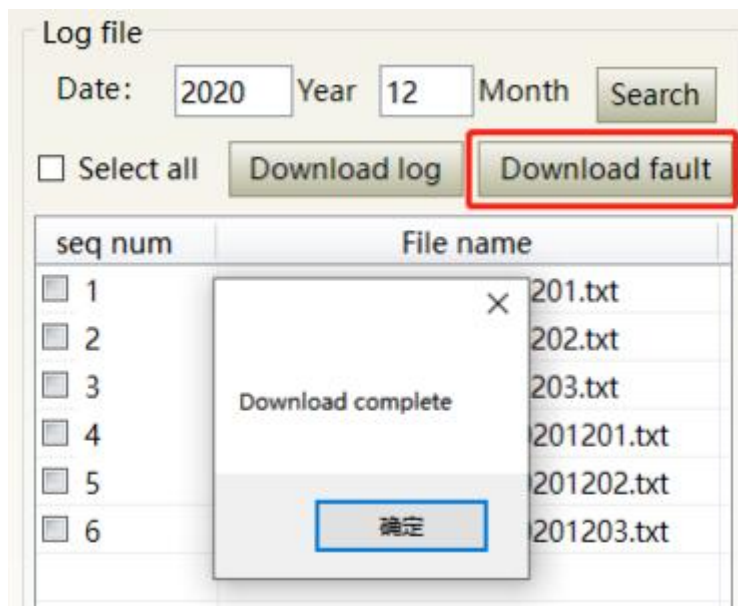

Figure 47 Historical fault record download interface



### 8.11.3 Downloaded file address

The file address query interface for all download information is as Figure 48.



Figure 48 The file address query interface for all downloaded information

### 8.12. Module parameters (in diagnostic mode)

Laser module parameter query interface is as Figure 49. The interface is for the parameter query in diagnostic mode from which Raycus technicians can analyze the cause of laser anomalies.



Figure 49 Module parameters query interface in diagnostic mode

### 8.13. Programming settings (programming editing)

The laser programming settings interface is as Figure 50.

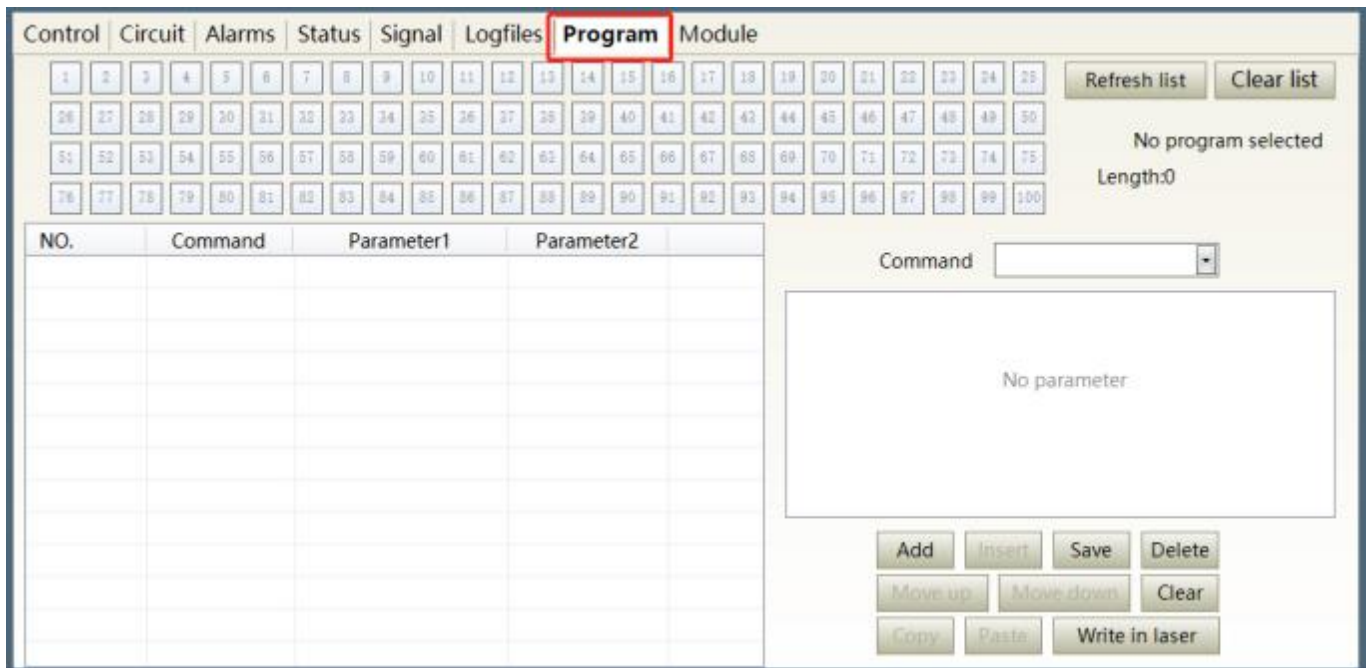

Figure 50 The programming interface in programming editing mode

### 8.13.1 View the number of wave bars inside the current laser

Operating interfaces of view the number of wave bar stored inside the current laser is as Figure 51. The software automatically lists the number of wavelength bars that have been saved by click on the „Refresher List“ button. Green indicates the bar already has a program and white indicates that the bar is empty.

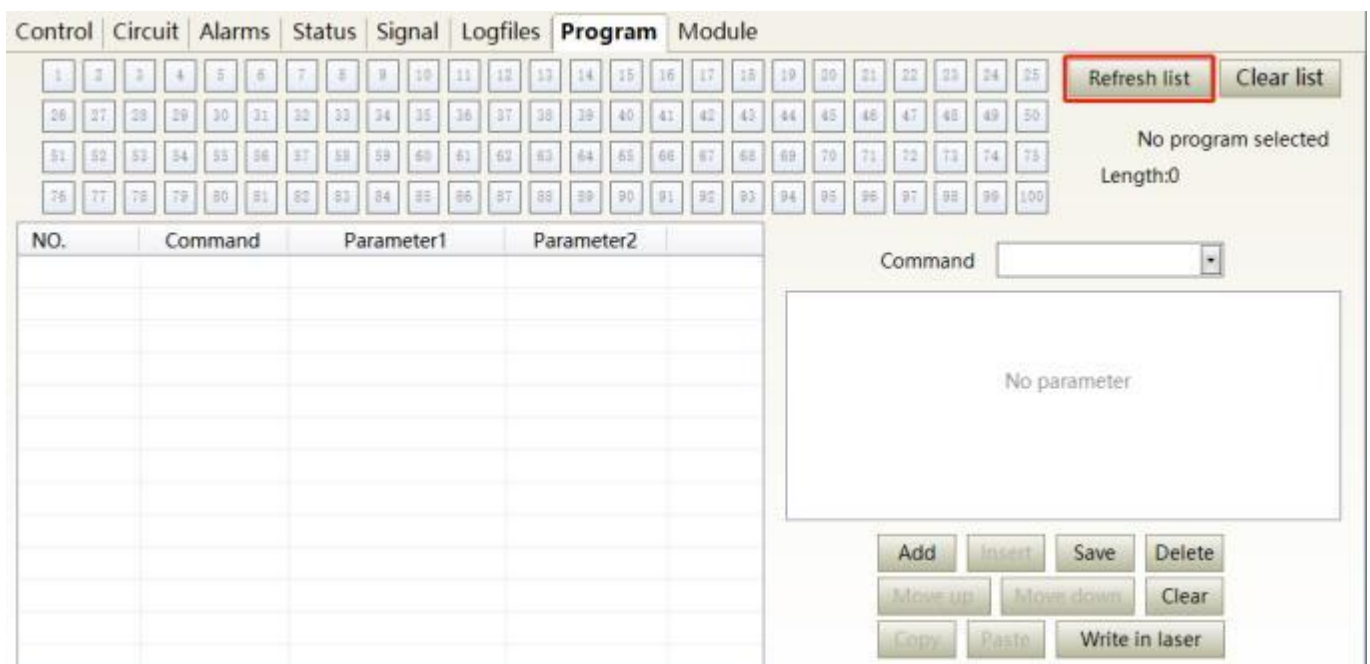

Figure 51 operating interfaces of wave bar stored inside the current laser

### 8.13.2 Check waveform content

To check the programming contents in the current laser programming mode is as Figure 52. The program automatically lists the original programmings by click the programming number that needs to be checked.

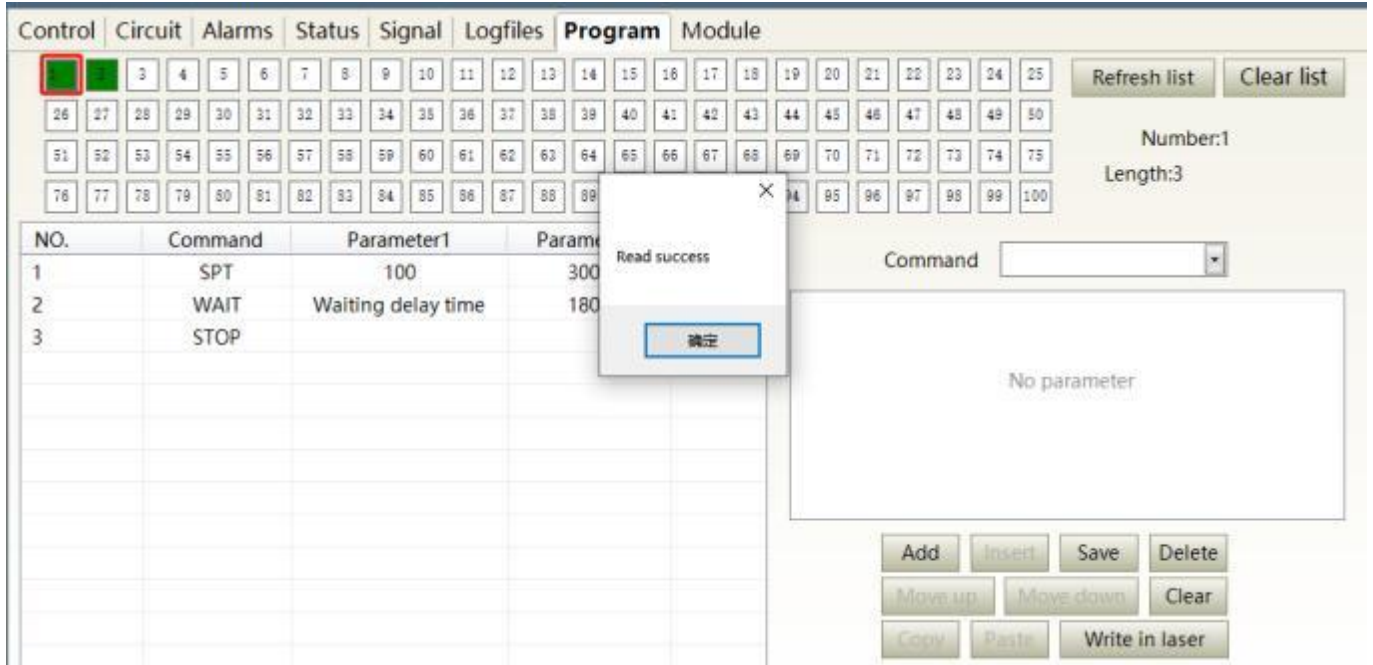

Figure 52 Programming content interface in the current laser programming mode

### 8.13.3 Empty all waveforms

Empty all programming interfaces stored in the current laser programming mode is as Figure 53. All programmings stored inside the current laser. will emptied by click „Empty Program List“.

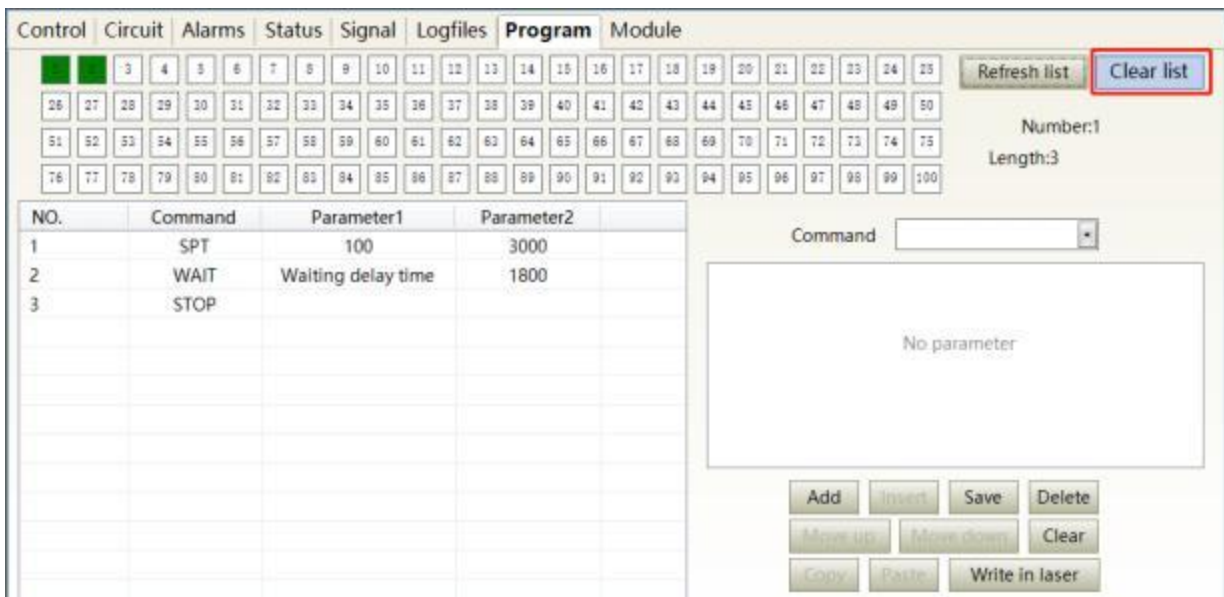

Figure 53 Interface of empty all programming stored in the current laser programming mode

### 8.13.4 Editwaveform

Programming editing when the laser is working in programming mode is as Figure 54.

Step 1:left click the pre-edited programming number.

Step 2:select the command under the command type, click „Add“.

Step 3:enter the parameters and click „Save“. The instruction appears in the left program list immediately.

Step 4:after editing all commands, click „Write Laser“.

Step 5:the new programming number will turn green when user re-click the „refresher list“ button.

Write successfully.

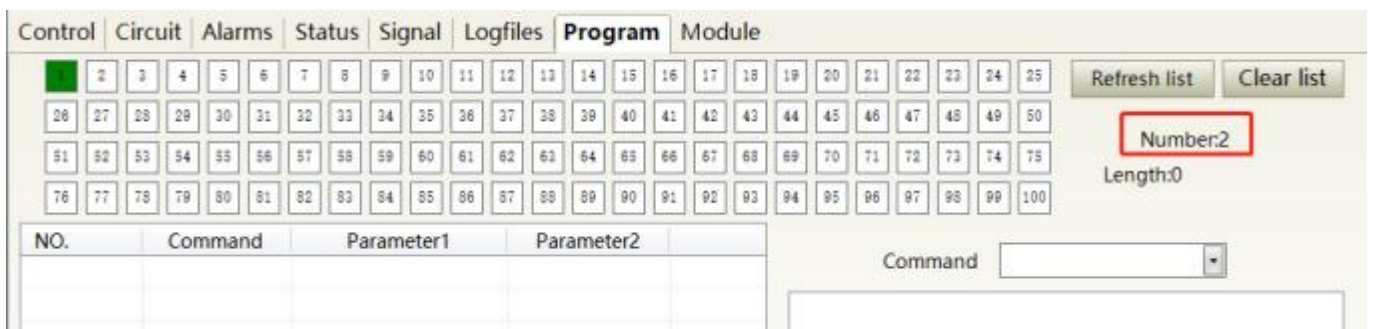

a) Select the pre-edited programming number

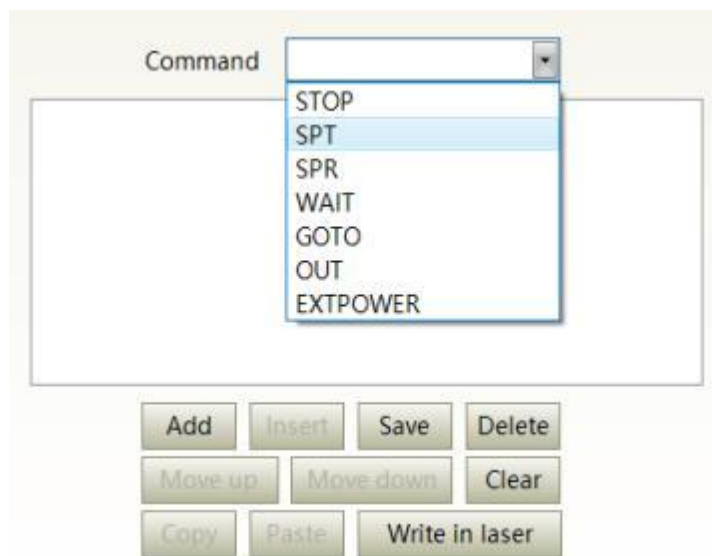



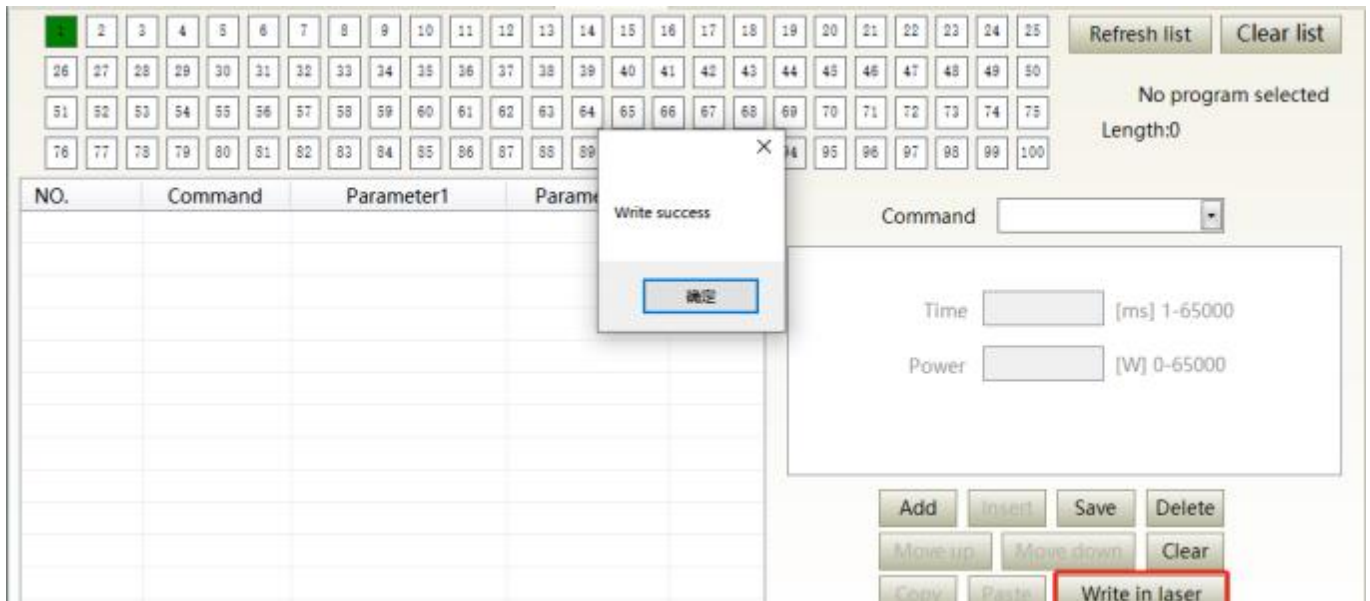

d) type the command code into laser



e) check effectiveness of instruction

Figure 54A diagram of the programming editing operation in programming mode

### 8.13.5 Command explanation

Command meaning in laser working status is as Table 17.

Table 17 command meaning in laser working status

Code (1 Byte)		Parameter1(2 bytes)		Parameter 2 (4 bytes)		Note
1	Stop	none		none		The program end command. the last command must be this command.
2	SPT	0~65000 (ms)		0~65000(W)		Change power to 2 in time 1
3	SPR	0~65000 (W/ms)		0~65000(W)		Change power to 2 in power change ratio 1
4	WAIT	1	Wait for sync signal low level	Null		
		2	Wait for sync signal high level	Null		
		3	Wait for sync signal rising	Null		
		4	Wait for sync signal dropping	Null		
		5	Wait	0~65000ms(int)		
5	GOTO	0~99	line	-1	Switch at low sync signal	Jump to different line when comply
		0~99	line	-2	Switch at high sync signal	Jump to different line when comply
		0~99	line	0 ~ 1000000	timesofjump to subject line	Times of loop jump to subject line
6	OUT	1	SO	1	sync signal low level output	
				2	sync signal high level output	
7	EXT Power	1	0~10V			
		2				

## 9. Warranty, Repair and Return

### 9.1. General Warranty

After all the lasers manufactured according to the standard or non-standard model production documents are shipped, Raycus guarantees the products with material and technical problems and guarantees that they meet the specifications under normal use.

Raycus has the right to selectively repair or replace any product that has a material or technical problem during the warranty period. All products repaired or replaced during the warranty period only provide free warranty services for products with special problems. Raycus reserves the right to collect payment for products that have problems under normal use.

### 9.2. Limitations of Warranty

The warranty does not cover the maintenance or reimbursement of our product of which the problem results from tampering, disassembling, misuse, accident, modification, unsuitable physical or operating environment, improper maintenance, damages due to excessive use or not following the instructions caused by those who are not from Raycus. The customer has the responsibility to understand and follow this instruction to use the device. Any damage caused by fault operating is not warranted. Accessories and fiber connectors are excluded from this warranty.

According to the warranty, client should inform us within 31 days after the defect is discovered. This warranty does not involve any other party, including specified buyer, end-user or customer and any parts, equipment or other products produced by other companies.

	<p><b>WARNING:</b>It is the customer's responsibility to understand and follow operating instructions in this User Guide and specifications prior to operation-failure to do so may void this warranty. Accessories and fiber connectors are not covered by this warranty.</p>
---	--

### 9.3. Service and Repair

Do not open the device. There are no user serviceable parts, equipment or assemblies for user in this product. All service and maintenance shall be performed by qualified Raycus personnel.

Please contact Raycus as soon as possible when problems under warranty about maintenance happened to the product.

The product returned with permission should be placed in a suitable container.

If any damage happened to the product, please notify the carrier in document immediately.



#### **9.4. Scrap requirements**

The fiber laser equipment can be scrapped and recycled if it has reached its useful life or has serious faults and has no value for modification or repair, or meets other scrapping conditions stipulated in the safety technical specifications.

**Raycus reserve the right to make changes in design or constructions of any of our products at anytime without incurring any obligation to make changes or install the same on units previously purchased.**

**All the items within warranty and service above provided by Raycus are for users' reference; formal contents about warranty and service are subject to the contract.**

**Information contained in this document is subject to change without notice.**